



DTM Econo Trailer

- Suitable for drains up to 150mm
- Ideal for plumbers requiring an entry level machine
- Lightweight and easy to tow



Model	DTM Econo trailer
Pressure and Flow	Up to 200 bar / Up to 36 litres per minute (3000 psi / 8 gpm)
Pump	Hawk triplex plunger pump
Engine	21hp water cooled diesel
Water Tank	Twin tanks - 227 litres (50 gallons)
Frame	Box section steel shot blasted and powder coated
Hose Reel	Manually wound hose reel with 90m high pressure hose capacity
Dimensions	3050mm long x 1400mm wide x 1340mm high *
Weight	Dry weight from 550kg *
Suggested Accessories	- 3/8" Standard jetting hose - 60m (200 ft) - 3 x 3/8" Standard drain jets (3r, 3r1f & 6r) - 3/8" Safety leader hose - 3m (10ft) - 3/8" Drain jet extension - 9"

* All weights and dimensions are approximate

Flowplant Group Ltd
 Gemini House, Brunel Road,
 Churchfields Industrial Estate,
 Salisbury, Wiltshire. SP2 7PU
 United Kingdom



t: +44 (0)1722 325 424
 f: +44 (0)1722 411 329
 e: sales@flowplant.co.uk

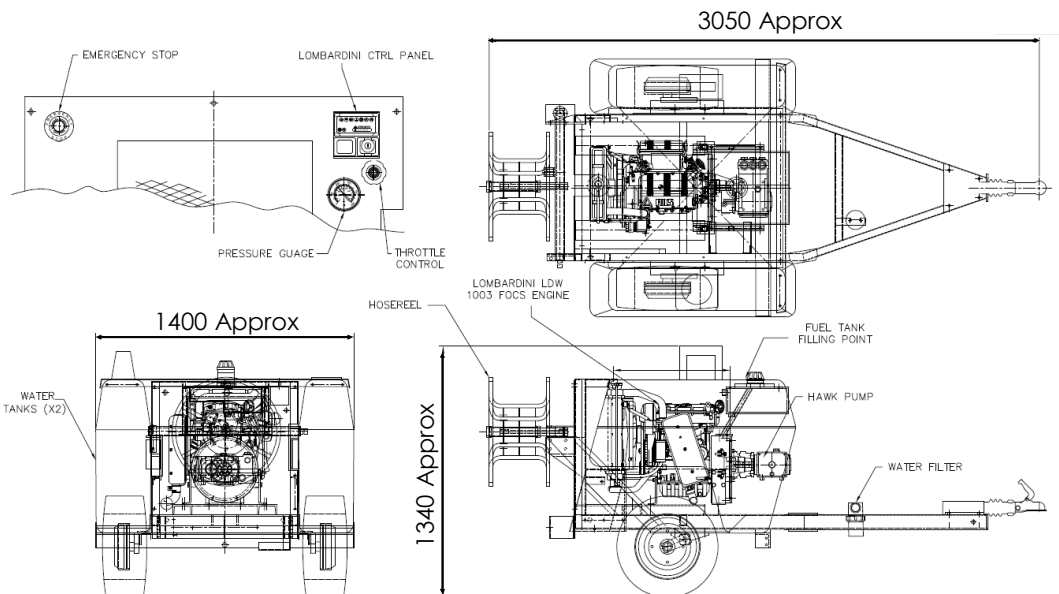

- High Pressure
- Cleaner Solutions



Flowplant Group Ltd provides the information herein in good faith but makes no representation as to its comprehensiveness or accuracy. This data sheet is intended only as a guide to Flowplant Group Ltd products and services. Individuals using this data sheet must exercise their independent judgment in evaluating product selection and determining product appropriateness for their particular purpose and system requirements. Flowplant Group Ltd MAKES NO REPRESENTATIONS OR WARRANTIES, EITHER EXPRESS OR IMPLIED, INCLUDING WITHOUT LIMITATION ANY WARRANTIES OF MERCHANTABILITY OR FITNESS FOR A PARTICULAR PURPOSE WITH RESPECT TO THE INFORMATION SET FORTH HEREIN OR THE PRODUCT(S) TO WHICH THE INFORMATION REFERS. ACCORDINGLY, Flowplant Group Ltd WILL NOT BE RESPONSIBLE FOR DAMAGES (OF ANY KIND OR NATURE, INCLUDING INCIDENTAL, INDIRECT, OR CONSEQUENTIAL DAMAGES) RESULTING FROM THE USE OF OR RELIANCE UPON THIS INFORMATION. Flowplant Group Ltd reserves the right to change product designs and specifications without notice.

Accessories can be viewed in our Drain Cleaning Accessories catalogue or online at <http://www.flowplant.com/drain-jetters/accessories/>

	Nozzles	Part No.
	3/8" Standard Drain Jet - 3r 3/8" Standard Drain Jet - 3r,1f 3/8" Standard Drain Jet - 6r	056693 056694 056695
	Mini Jet (Ball) - 3r Mini Jet (Ball) - 3r,1f	056126 056412

	Hoses	Part No.
	3/8" Standard Jetting Hose - 90m	055962
	3/8" Safety Leader Hose - 3m	055998

	Jetting Accessories	Part No.
	Mini Jet Kit - 6m - 3r1f Mini Jet Kit - 6m - 3r Micro Mini Jet Kit - 6m - 3r1f	023220 023227 032601
	Tiger Tail - 2"	0551443
	Spray Gun c/w 1.2m Barrel P&A Gun Spinning Nozzle - 2f	033362 056326
	3/8" Drain Jet Extension - 9"	057149
	Jet Pump - Output 50gpm Jet Pump - Output 45gpm	032121 032121
	Whirlaway - 0.45m Cleaning Width	057102

	Safety Equipment	Part No.
	Jetting Helmet Set	065013
	Jetting Safety Boots (Sizes 6 - 12)	TBC
	Waterproof Suit (Sizes S - XL)	TBC
	Gauntlet Gloves	065064
	Safety Burst Discs (Green)	011045
	Safety Sign	061054