

HARBEN
'P' TYPE PUMP
SERVICE MANUAL

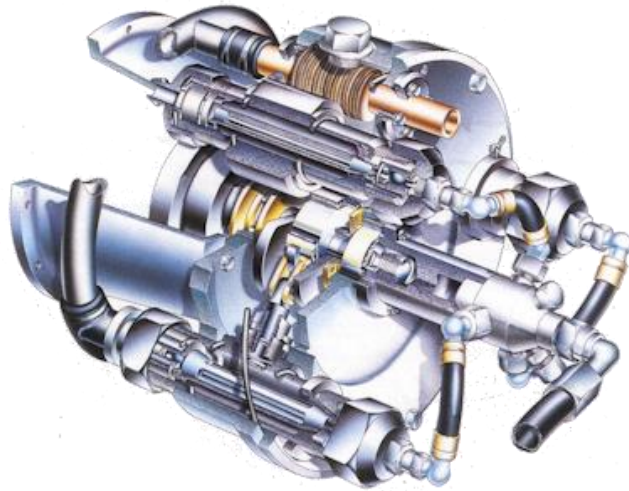

**This manual contains
IMPORTANT Safety Information**

**Flowplant Group Ltd.
Gemini House
Brunel Road
Churchfields Ind. Est.
Salisbury
Wiltshire, SP2 7PU
England**

**t : +44 (0)1722 325 424
f : +44 (0)1722 411 329**

**Harben Inc.
P.O.Box 2250
Cumming
GA 30028
USA.**

**t : +1 770 889 9535
f : +1 770 887 9411**

HARBEN

'P' TYPE PUMP SERVICE MANUAL

CONTENTS

FOREWORD

IMPORTANT SAFETY INFORMATION

SECTION 1 PUMP TECHNICAL DATA

SECTION 2 PUMP INSTALLATION

SECTION 3 GENERAL OPERATING INFORMATION

SECTION 4 PUMP MAINTENANCE AND OVERHAUL PROCEDURES

SECTION 5 WARRANTY

A detailed contents list precedes each section

FOREWORD`

This manual is primarily concerned with the Harben 'P' Type Pump. Details are also given of hot water and large bearing variants of the 'P' Type Pump, in addition, general safety and operating information for the equipment using the pumps is also included.

The conversion of pressurised water into a high velocity jet and its use as a cleaning and cutting tool is now familiar to, and used by, many people in a wide range of industries.

High pressure water can achieve remarkable results without the use of heat or chemicals and cost savings over conventional maintenance methods can in many cases show that a water jetting unit will pay for itself in hours rather than years.

Many companies have problems for which high pressure water offers a rapid solution, yet hesitate to consider this method because of the generally accepted high cost of such equipment. Backed by many years of design and manufacturing experience, Harben pumps are setting new standards of performance and reliability. The capital and operating costs are such that these offer an attractive return on investment that really makes sense.

Flowplant Group Ltd have a policy of continual research and improvement and reserve the right to make such modifications and design changes as are considered necessary in the light of experience, however, this copy of the manual will not be amended.

No part of this manual may be reproduced or copied in any manner without written permission from Flowplant Group Ltd.

HEALTH AND SAFETY AT WORK

There are two main categories of risk. These are:

- a) Injury from impact of water
- b) Injury from environment

All persons involved in water jetting should be made aware of the risks.

INJURY FROM IMPACT OF WATER

In the event that a person is injured by the impact of a water jet, the injury caused may appear insignificant and give little indication of the extent of the injury beneath the skin and the damage to deeper tissues. Large quantities of water may have punctured the skin, flesh and organs through a very small hole that may not even bleed.

Immediate hospital attention is required and medical staff must be informed of the cause of the injury. To ensure that this is not overlooked, all operators engaged on jetting should carry an immediately accessible waterproof card which outlines the possible nature of the injury and bears the following text which has been endorsed by the Employment Medical Advisory Service (EMAS) of the Health and Safety Executive:

THIS MAN HAS BEEN INVOLVED WITH HIGH PRESSURE WATER JETTING AT PRESSURE UP TO 36750 LB/IN² (250 MPA, 2500 BAR, 2548 KG/CM²) WITH A JET VELOCITY OF 1536 MILES (2458 KM) PER HOUR.

Please take this into account when making your diagnosis. Unusual infections with micro-aerophilic organisms occurring at lower temperatures have been reported. These may have gram negative pathogens such as are found in sewage. Bacterial swabs and blood cultures may therefore be helpful.

A letter containing this and other relevant information should be sent to the doctor of each operator.

Where surgical examination is not immediately possible in remote situations, first aid measures should be confined to dressing the wound and observing the patient closely until a medical examination has been arranged.

If any person, object or article is accidentally struck by the jet, this fact must be reported to the occupier's representative.

INJURY FROM ENVIRONMENT

Work should only be carried out if it is safe to do so. A thorough examination of the site should be carried out before work is started. Refer to the Warnings and Cautions.

Special care should be taken where there is a danger of infection; there are many situations where infection can take place. As a guide to avoiding infection, the following points should be considered:

- a) Full protective clothing must be worn.
- b) Always clean scratches or cuts immediately. Disinfect and cover with a strip of gauze and impermeable plaster. **SEEK MEDICAL HELP**
- c) Avoid rubbing eyes, nose or mouth with hands during working.
- d) All contaminated clothing, vehicles and equipment should be thoroughly cleaned.
- e) Operators should wash thoroughly after work and before eating, drinking or smoking.

SAFETY CODE OF PRACTICE

Full details of the Safety Code of Practice, when working with equipment containing a Harben pump, are given in Section 3 of this manual. The basic rules of this code are as follows:

1. ALWAYS WEAR THE CORRECT PROTECTIVE CLOTHING.
2. ALWAYS ENSURE ALL EQUIPMENT IS IN A FIRST CLASS CONDITION.
3. NEVER WORK FROM A LADDER.
4. NEVER USE THE GUN WITH THE TRIGGER LOCKED ON.
5. NEVER POINT THE GUN AT ANYONE, EVEN IF SWITCHED OFF.



Only a responsible person who has received instruction in the operation of high pressure water jetting equipment should be allowed to operate the equipment.

POTENTIAL HAZARDS AND MISUSE OF HIGH PRESSURE EQUIPMENT



Failure to follow the instructions where this icon is shown can result in serious injury or even death



- Never use a jetter that isn't regularly serviced according to the manufacturer's recommendations.
- When a jetter is used to clean drains & sewers that are contaminated with a hazardous substance it is possible these may be entrained in the resulting aerosol and inhaled by operators. Consider using respiratory protection.
- Do not spray flammable liquids - there is a risk of explosion. 
- Ensure the correct fuel is used on all occasions or there is a risk of explosion. 
- Never start the jetter when frozen. Operating a jetter whilst frozen could cause high speed ice bullets to be ejected from the jetter hose on machine start up.
- Never start jetting a drain, sewer or pipe unless the jet nozzle is safely inside the drain and pointing in the direction that you intend it to travel.
- When drain jetting a drain, sewer or pipe with an inside diameter that is not small enough to prevent the hose from turning back on itself, a drain jet extension (a piece of straight rigid tube equivalent to the pipe diameter) should be fitted between the end of the hose and the nozzle.
- Always use a safety leader hose at the beginning of the main jetting hose to alert operators when the jet nozzle is nearing the manhole entrance.
- Always consider the use of a tiger tail hose feed guide to protect the jetting hose from abrasion and prevent premature failure.
- Be aware that high pressure hoses can generate static electricity which may need to be controlled when working in hazardous areas.
- Never direct a high pressure water jet at electric power lines or electrical equipment as serious injury or death from electrocution could occur. 
- When jetting drains or sewers if there is a danger to the general public from hoses laying across public walkways they must be covered in such a way as to protect against injury from hose failure and tripping hazards.
- Before starting work, check and ensure the drain jets have no blocked holes or nozzles as this may cause the pumping system to over pressurise which could result in burst disc failure or bursting the jetting hose.
- Never attempt to unblock a fully choked drain or pipe before considering the consequence of releasing the blockage and having a plan to deal with it. E.g. flooding, material ejection, drain nozzle ejection.
- Never attempt to clean drains or pipes in one pass because this could lead to debris build up behind the jet nozzle causing a pressure build up in the drainage system. Be aware that a pressure build up in the drain or pipe could cause the jet nozzle to be ejected at speed back towards the operator.
- Never enter the manhole to either place the jet nozzle into or extract it from the drain entrance unless the required confined space regulations have been met.
- Never work in a manhole with a radio remote control transmitter that is not classified for use in such areas.

POTENTIAL HAZARDS AND MISUSE OF HIGH PRESSURE EQUIPMENT – CONT'D

Failure to follow the instructions where this icon is shown can result in serious injury or even death



- Never use the hydraulic hose reel facility as a winch to retract a jetting hose that has become stuck in the drain or pipe. Damage to the hose could be caused that will make subsequent hose failure more likely.
- Never allow jetting hoses to become kinked and always remove from service any jetting hose with an outer cover that has worn through to the reinforcing braid.
- Never use the high pressure jetting hose for any purpose other than sewer, drain or pipe cleaning, e.g. winching vehicles or other plant.
- Never use jetting nozzles and/or accessories that have not been calibrated for the jetting machine pump performance as this could cause rapid over pressurisation catching operators unaware.
- Never attempt to clean a drain or pipe with a nozzle that has more forward force than rear force. It could be ejected back toward the operator causing injury.
- Never attempt to clean a drain or pipe with a chain flail type jet that has unequal chain lengths as this could lead to severe vibration and high pressure hose failure.
- When using a venturi jet pump to remove fluid from a flooded manhole never place your fingers into the pump inlet as they could be trapped by the vacuum and cause injury.
- When using a venturi jet pump to remove fluid from a flooded manhole always secure the free end of the pump hose securely and ensure adequate drainage is in place to deal with high volumes of pumped water.
- Never use a dry shut type foot control valve on a jetter that does not have a pressure unloader valve as this could result in burst disc failure or bursting the jetting hose.
- When using a dry shut type system be aware that high pressure can be retained in the jetting hose even after the machine has been shut down. Always discharge pressure in a safe manner after machine shut down.
- When working with a gun always consider using a safety shroud to provide the operator with greater protection in the event of a hose burst.
- Never point the gun at anyone as injury from high pressure water will occur if the jet stream comes into contact with body parts.
- Never work on a slippery surface because the reaction force of the jetting gun could cause you to become unstable and lose your footing.
- Never work from a ladder as the reaction force of the jetting gun could cause the ladder to fall backwards from the working area causing possible injury.
- Never work from scaffolding unless it is designed, erected and managed by competent persons and it is adequately secured to prevent it being pushed over by jetting gun reaction forces.
- When using the jetting gun to clean hard surfaces be aware that splash back could contain hard debris travelling at speed.
- When using the jetting gun to clean contaminated surfaces be aware that splash back could contain dangerous contaminants.
- Never use the jetting gun to clean a surface that could be damaged or penetrated by the water pressure unless that is the desired effect.

POTENTIAL HAZARDS AND MISUSE OF HIGH PRESSURE EQUIPMENT – CONT'D

Failure to follow the instructions where this icon is shown can result in serious injury or even death



- Always ensure that an adequate area is cordoned off around the working zone so that flying debris and contamination cannot injure passers-by.
- Be aware that the use of water jetting guns fitted with oscillating or rotating heads tend to produce higher hand arm vibration levels than simple fixed head jets.
- When using a jetting gun or nozzle to clean at floor level wear suitable protective foot wear.
- Never use a high pressure jetting gun to clean down PPE whilst you or others are still wearing it as serious injury and death could result.
- Never use a high pressure jetting gun to wash or cool down livestock as serious injury and death could result.
- Drainage systems may carry bacteria and micro-organisms which can cause severe illness or death. Avoid exposing eyes, nose, mouth, ears, hands, cuts or abrasions to waste water or faecal matter during drain cleaning operations. After working around drainage systems help protect yourself by always washing hands.

**Personal Protective Equipment (PPE)**

All persons using high pressure water jetting equipment should use all necessary PPE suitable for the task being carried out. This includes, but is not limited to:

- Ear protection
- Eye protection: a helmet with chin guard and visor is recommended
- Hand protection
- Waterproof clothing
- Safety boots with toe protection

Please note: A site specific risk assessment must be completed to analyse which PPE must be worn.

SECTION 1

TECHNICAL DATA

SECTION 1**TECHINCAL DATA****CONTENTS**

	<u>Para</u>
Introduction	1
Pump Description	
Function	4
Filtration	9
Fluid Flow	10
Pump Barrel Options	
'P' Type Barrels	11
Identity	
Manufacturer	16
Pump Identification	17
Design and Performance Data	
Physical Data	18
Performance Characteristics	19
Equipment Details	20
Associated Publications	21

ILLUSTRATION

<u>Fig</u>		<u>Page</u>
1.1	Harben 'P' Type High Pressure Pump	19

TABLES

<u>Table</u>		<u>Page</u>
1.1	Pump Performance Data - Maximum Working Pressures	15
1.2	Performance Data - 'P' Type Pump and Horsepower Required	16
1.3	Performance Data – 'P' Pump and Horsepower Required	17
1.4	Equipment Serial Numbers and Jet Sizes	18

TECHNICAL DATA

INTRODUCTION

1. The Harben 'P' Type high pressure pump (Fig 1.1) is a radial piston diaphragm pump which can be used for a number of industrial applications, including the following:
 - (1) High pressure cutting of board, plastic and other materials
 - (2) Water hydraulic systems
 - (3) Abrasive blasting and descaling
 - (4) Drain/sewer cleaning
 - (5) Tube descaling
 - (6) Desalination by reverse osmosis
 - (7) Pumping demineralised water
 - (8) Floor and surface cleaning
 - (9) Underwater cleaning.

2. In addition to its reliability and long service intervals, the advantages of using this type of pump include:
 - (1) Variable pressure and flow options without piston change
 - (2) Pumps can run dry without damage as there are no piston seals
 - (3) Filtration of 50 to 177 microns
 - (4) No modification is required to pump sea water (Flushing with potable water recommended)
 - (5) Pump has multi-cylinders therefore no pulsation
 - (6) Positive displacement thus high efficiency.

3. The pump is designed to be directly-coupled and flange-mounted, and can be supplied in either bare-shaft form, or skid mounted, trolley mounted, trailer mounted or truck mounted configurations. In addition, the pump can be mounted on an underwater ROV. Diesel drive, electrical drive and hydraulic drive options are available.

PUMP DESCRIPTION

Functional

NOTE The following description of the Harben 'P' Type Pump applies equally to the 'High-Lift' variant of the pump. Performance details of each type of pump are given later in this section.

4. The 'P' pump works on the radial piston design principle which uses one-way valves in conjunction with tubular diaphragms, fitted with an internal support or mandrel. The pumped fluid, which passes through this diaphragm, is enclosed by a cylindrical pressure chamber or barrel, in the ends of which are fitted inlet and delivery valves.
5. The pump crankcase, which contains the only moving parts, is filled with mineral hydraulic oil. This oil provides for the lubrication of all moving parts within the crankcase, and as a means of pressure to compress the diaphragm.
6. As the pump shaft rotates, the piston advances and its ports pass the end of the cylinder, sealing the chamber. Further advance of the piston causes the trapped oil to compress the diaphragm around the mandrel, expelling the water in the diaphragm through the delivery valve and into the delivery manifold.
7. When the piston retreats, the diaphragm reverts to its tubular form and draws water through the inlet valve. Any oil slippage past the piston during the delivery stroke is made up through the piston ports as they open to the crankcase oil.
8. All mechanical parts, with the exception of the inlet and delivery valves, run in the oil-flooded crankcase and are therefore unaffected by contamination by the pump fluid, or by running dry.

Filtration

9. Standard filtration for the pump is normally between 50 and 177 microns. This filter is usually fitted to the inlet of the supply tank or reservoir. This arrangement ensures that if the filter is neglected to the point of blockage, the tank will empty and the pump will run dry, thus enabling the dry-running qualities of the pump to be used as a filter maintenance indicator. Inlet conditions required are flooded suction; pressure feeding is not necessary.

Fluid Flow

10. Arrangements are made on the pump for the incoming fluid to cool the crankcase oil. The use of standard diaphragm/barrel assemblies provides a choice of flows, depending upon the number of barrels fitted to a crankcase. The cylindrical form of these barrels is well suited to containing

high pressures. Three piston diameters are available to suit a range of pressure up to 420 bar (6000 psi).

PUMP BARREL OPTIONS

'P' Barrels

11. 'P' type barrels now come in one material EN57 (Spec 431 529) stainless steel for pressures up to 415 bar (6000 psi).
12. The barrels are always supplied as an assembly including baffle plate (part no 012 001), seal (011-011) and inner cylinder. The diameter of the cylinder varies for different pump performances. Diameters available are 18 mm, 20 mm and 22 mm.
13. All barrels are given a letter code to indicate their position in the crankcase (refer to Section 4, Fig 4.2). This letter code can be found stamped on the face adjacent the inner cylinder. Letters A to M are used. Each letter is given a part number.
14. When ordering spare barrels, each part number requires cylinder diameter and barrel material letter options. The option code is shown as two letters. The first indicates the barrel material - A is for EN57 and B is for EN1A. The second indicates the cylinder diameter - A is for 18 mm, B is for 20 mm and C is for 22 mm.
15. The part numbers for barrels are as follows (it should be noted that pistons are ordered separately):

	Barrel Part No.	Letter Code	
Key:	011-250	Barrel 'A'	
	011-251	Barrel 'B'	
	011-252	Barrel 'C'	
	011-253	Barrel 'D'	Barrel material –
	011-254	Barrel 'E'	A = EN57
	011-255	Barrel 'F'	B = EN1A (This option has been withdrawn)
	011-256	Barrel 'G'	
	011-257	Barrel 'H'	Cylinder diameter –
	011-258	Barrel 'J'	A= 18mm
	011-259	Barrel 'K'	B = 20mm
	011-260	Barrel 'L'	C = 22mm
	011-261	Barrel 'M'	

For example '011-252AB' is a 'C' barrel in EN57 ST/ST with 20 mm cylinder.

IDENTITY**Manufacturer**

16. The Harben Pumps are manufactured by:

Flowplant Group Ltd.

Gemini House

Brunel Road

Churchfields Industrial Estate

Salisbury

Wiltshire, SP2 7PU

ENGLAND Tel: +44 (0)1722-325424 Fax: + 44 (0)1722-411329

Pump Identification

17. A pump specification label is fitted on the pump crankcase, adjacent to the oil filler cap. This label will give the pump type (no. of cylinders, piston/cylinder diameter), pump serial number, the type of oil to be used (Shell Morlina or equivalent), the maximum working speed (std - 1250 rpm), the maximum working flow, and the pump's year of manufacture.

Note: The serial number followed by 'LB' or 'HW' indicates a large bearing or hot water P pump variation.

For example:

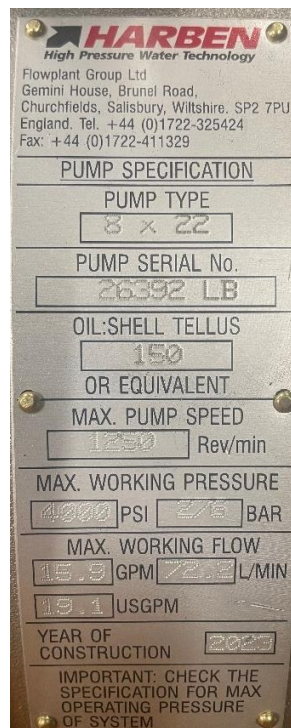

DESIGN AND PERFORMANCE DATAPhysical Data

17. Pump diameter - 405 mm
 Pump length - 385 mm
 Inlet - 28.6 mm dia
 Outlet - 1/2 in SSP
 Shaft diameter - 30 mm
 Shaft length - 65 mm

Performance Characteristics

18. For full details of the 'P' Type Pump performance data, reference should be made to the appropriate information given in Tables 1.1, 1.2 and 1.3.

TABLE 1.1 PUMP PERFORMANCE DATA - MAXIMUM WORKING PRESSURES

Pump/Cylinder Diameter	'P' Type 1000 - 1250 rpm	
	EN1A	EN57
18 mm	4000 psi (280 bar)	6000 psi (420 bar)
20 mm	4000 psi (280 bar)	5000 psi (350 bar)
22 mm	4000 psi (280 bar)	4000 psi (280 bar)

- NOTES** (1) EN1A and EN57 denote barrel materials. EN1A is mild Steel with a Cadmium plating, whilst EN57 is Stainless Steel - self finish. (EN1A barrels have now been withdrawn and replaced with EN57)
- (2) As a rule electrically-driven pumps run at 1000 rpm and diesel-driven pumps run at 1250 rpm.
- (3) Quantity of cylinders does not alter pump working pressure.

Equipment Details

19. Details relevant to the pump and associated equipment should be entered on the form shown in Table 1.4, at the rear of this section, for future reference.

ASSOCIATED PUBLICATIONS

20. Associated with this manual are the following publications:

Operators Guide - Part No. 061-225

Code of Practice - Part No 057-062

Guide Do and Don't Booklet - Part No. 081-259

TABLE 1.2 PERFORMANCE DATA – 'P' TYPE PUMP HORSEPOWER REQUIRED

PERFORMANCE DATA FOR 'P' TYPE PUMP AND HORSEPOWER REQUIRED

GRAPH SHOWS STANDARD P TYPE PERFORMANCE @ 960 RPM.
(6 POLE ELECTRIC MOTOR)

NOTE:-FOR PERFORMANCES OVER 4000 PSI, SPEC:441S49 (EN57)
STAINLESS STEEL BARRELS MUST BE USED.
SEE SEPERATE GRAPH FOR HI-LIFT, 1250 RPM PERFORMANCE (DIESEL)

PSI BAR

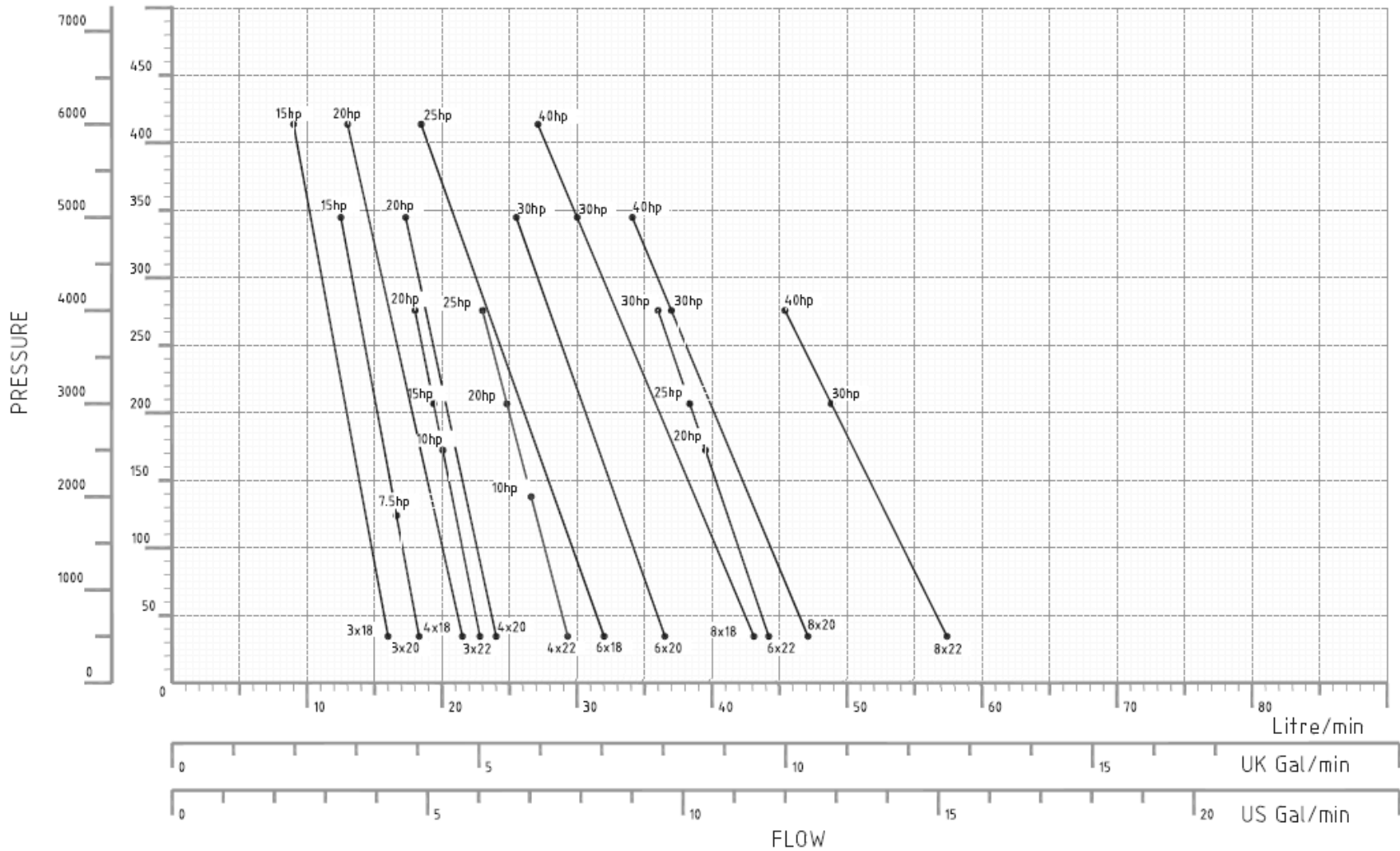

TABLE 1.3 PERFORMANCE DATA – P TYPE PUMP HORSEPOWER REQUIRED

PERFORMANCE DATA FOR HIGH LIFT PUMP AND HORSEPOWER REQUIRED

GRAPH SHOWS 'P' PUMP PERFORMANCE @ 1250 RPM.
(DIESEL ENGINE/GEARBOX)

SEE SEPERATE GRAPH FOR 'P' PUMP PERFORMANCE @ 960 RPM
(ELECTRIC MOTOR)

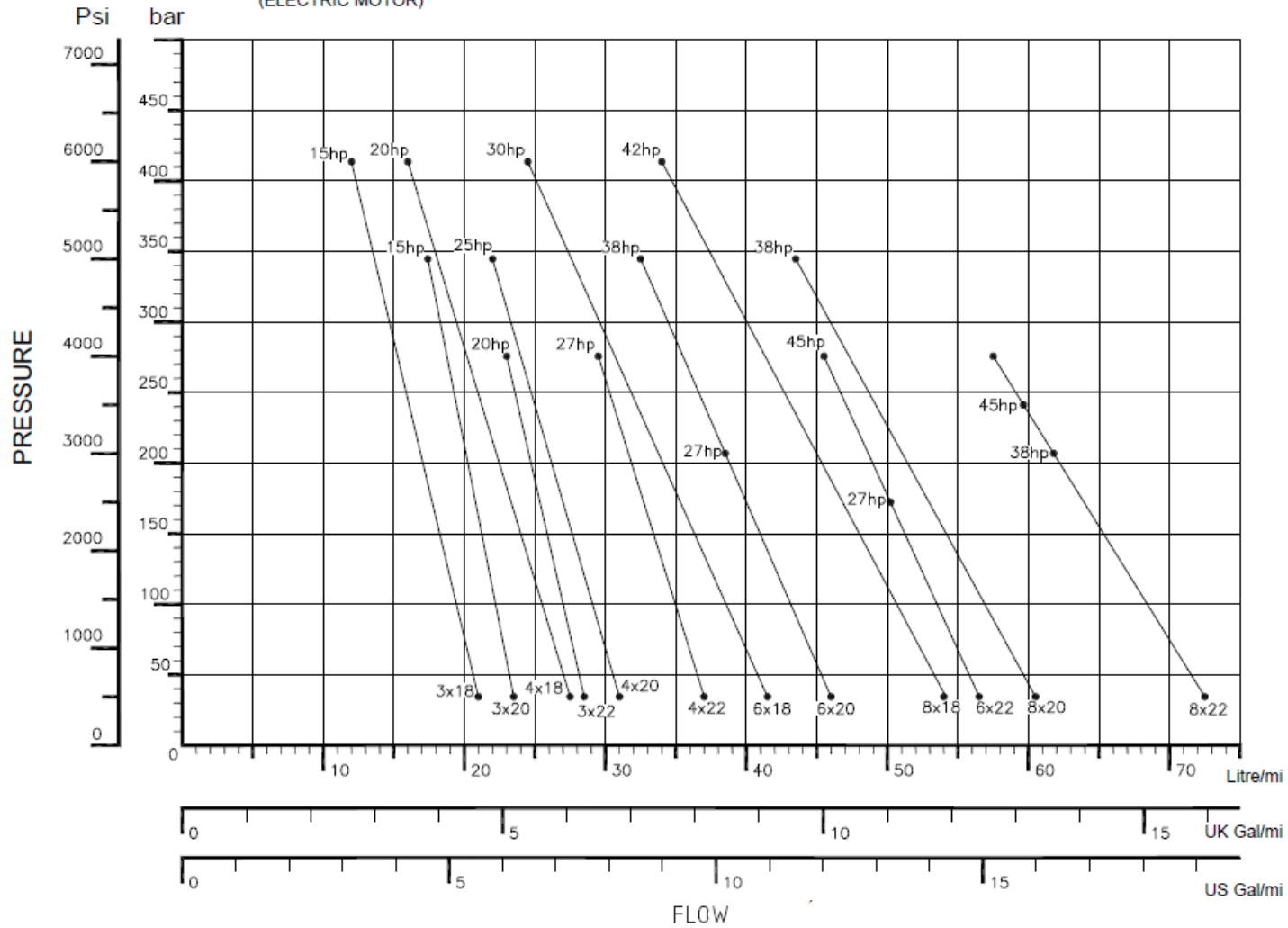
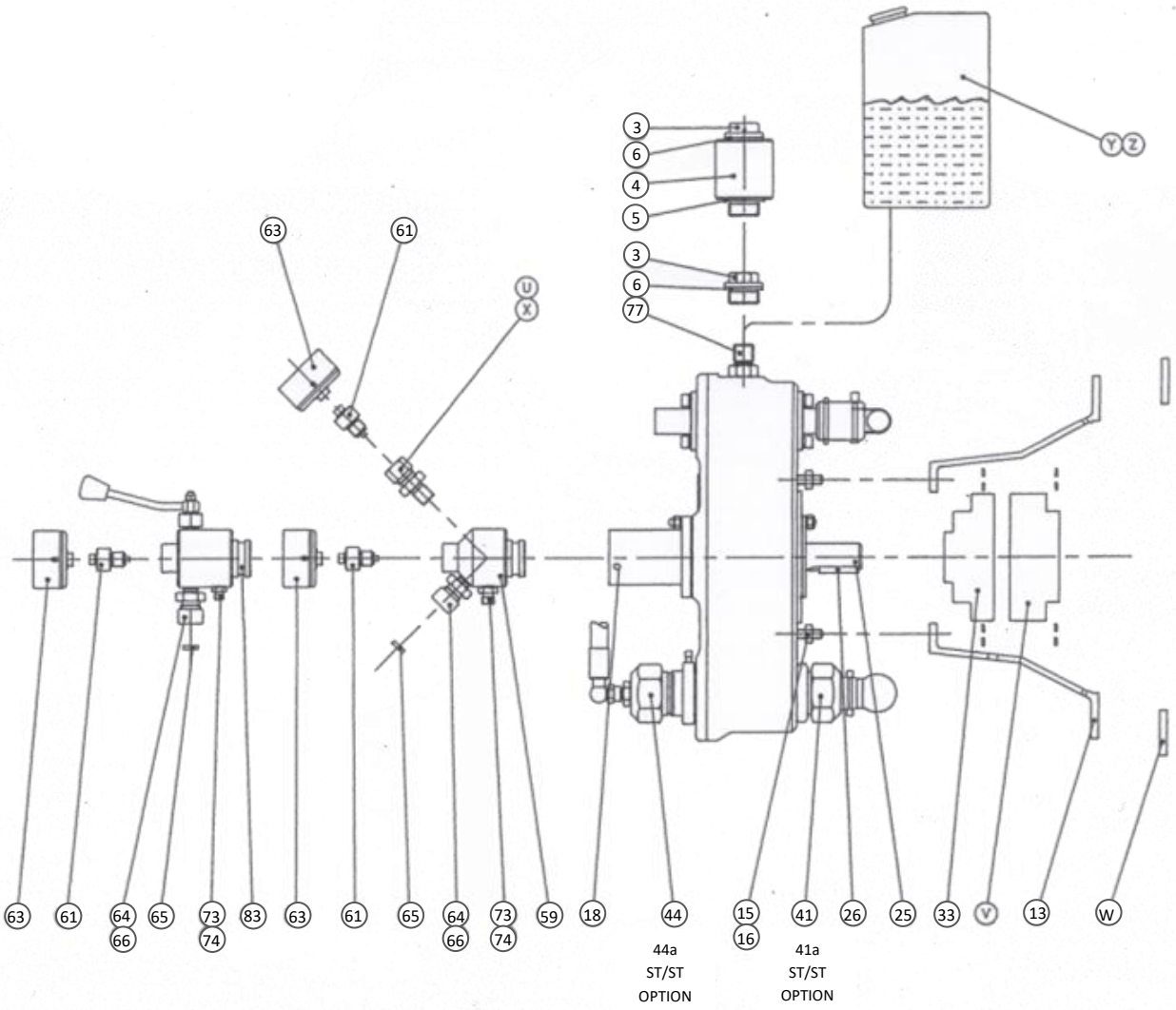

TABLE 1.4 EQUIPMENT SERIAL NUMBERS AND JET SIZES

Pump Type	Pump Serial No(s)	
Engine Type	Engine Serial No	
Gearbox Type	Gearbox Serial No	
Motor Frame/kW	Motor Serial No	
Maximum Working Pressure of pump		
Maximum Flow at Above Pressure		
Single Gun High Velocity Jet Size		
Single Gun 15 Degree Jet Size		
Twin Gun High Velocity Jet Size		
Twin 15 Degree Fan Jet Size		
Twin Gun Choke Size		
Type of Safety Gun Supplied		
Standard Drain Jets		
3 Rear drain jet		
6 Rear drain jet		
3 Rear 1 forward drain jet		
High Efficiency Drain Jets		
3 Rear HE drain jet		
6 Rear HE drain jet		
3 Rear 1 forward HE drain jet		
Mini Jet Kit 20'	50'	
Turbo/Dia 38mm Screma Jet	Dia 16mm Screma Jet	
Jet Leader		
Plough Jet		
Jet Pump.....	Type.....	Jet sizes.....
Hoverclean		
Hovervac		
This pump unit and all the accessories listed above have been test at:		
.....bar psi.....		



ITEM	DESCRIPTION	PART NUMBER
83	SELECTOR	***
U	PLUG	013-017
V	N-EUPEX COUPLING FEMALE	023-087
33	N-EUPEX COUPLING MALE	023-093
W	ADAPTOR RING	***
X	SNAP COUPLING BODY	013-015
Y	OIL EXPANSION ASSY	100-290
Z	OIL POLLUTION	100-648

(I) STANDARD BUILD OF BARE SHAFT PUMP
(* = INCLUDED IN BUILD)

		'P' PUMP 020-				'HL' PUMP 019-			
		30YL	40YL	60YL	80YL	30YL	40YL	60YL	80YL
1	KEY DRIVE SHAFT	*	*	*	*	*	*	*	*
15-16	NUTS & WASHER FOR BELLHOUSING	*	*	*	*	*	*	*	*
3-6	BREATHER CAP & SEAL	*	*	*	*				
4-5	EXPANSION CHAMBER & SEAL			*	*				
* 77	ADAPTOR 1" BSP x 1/2" BSP & SEAL					*	*	*	*
** 18	SOCKET HD SET SCREW	*	*	*	*	*	*	*	*
64	PRESSURE DISC HOLDER	*	*	*	*	*	*	*	*
*** 65	PRESSURE DISC (8 OFF)	*	*	*	*	*	*	*	*

* CRANKCASE FITTED, ADAPTOR SUITABLE FOR CONNECTION TO OIL EXPANSION BOTTLE.
 ** 8 OFF SOCKET HD SET SCREW FOR PUMP AND MOTOR COUPLING.
 *** WORKING PRESSURE WILL DETERMINE DISC TYPE.

EXAMPLE TO OBTAIN PART No:-

INFO: A 4cyl x 22mm STD PUMP WITH EN1A BARRELS
 DRIVE COUPLING, BRASS NUTS, DELIVERY SELECTOR
 AND GAUGE.

Flowplant P Pump Manual Issue 10

- FROM TABLES (i) & (ii), WE CAN OBTAIN THE PART No AS FOLLOWS:-
 1) TABLE (i) TO FIND THE TYPE OF PUMP ie STD P OR HL PUMP - 020
 2) TABLE (ii) WE CAN FIND THE SECOND PART BY USING THE 4cyl, 22mm AND THE MATERIAL TYPE EN1A, TO GIVE - 018
 3) TABLE (ii) PROVIDES THE FINAL PART OF THE CODE, BY CHOOSING 1 ITEM PER COLUMN WE GET:-
 a) DRIVE COUPLING FROM COLUMN 1 GIVES - LETTER B
 b) BRASS NUTS FROM COLUMN 2 GIVES - LETTER A
 c) DELIVERY SELECTOR FROM COLUMN 3 GIVES - LETTER D
 4) THEREFORE THE PART No = 020-018-BAD

(ii)		STD 'P' PUMP 020 AND HL PUMP 019			
		3	4	6	8
18	EN1A	-008	-010	-011	-012
	ST/ST	-001	-002	-003	-004
20	EN1A	-013	-014	-015	-016
	ST/ST	-005	-006	-007	-008
22	EN1A	-017	-018	-019	-020
	ST/ST	-038	-039	-040	-041

(iii)	1	2	3
A.	BARE SHAFT 14, 26, 3, 18	BRASS NUTS 41, 44	BARE DELIVERY 64, 65, 59
B.	DRIVE COUPLING 14, 26, 3, 18, U	ST/ST NUTS 41a, 44a	DELIVERY MANIFOLD 64, 65, 59
C.	N/A	N/A	DELIVERY MANIFOLD AND GAUGE 64, 65, 59, 65, 61, 63
D.	N/A	N/A	DELIVERY SELECTOR 64, 65, 66, T
E.	N/A	N/A	DELIVERY SELECTOR AND GAUGE 64, 65, 66, T, 61, 63

British Flowplant Group will recommend a model of pump and part number based on the customers requirements, pressure and flow required pump speed and pump options. This recommendation by part number will specify
 I. Cylinder quantity
 II. Cylinder size
 III. Barrel material
 IV. Inlet valve selection
 Performance

Features included as standard in this selection can be seen in chart (i)

Option selection for features relating to function can be seen in chart (iii) and viewed in fig 1.
 To use option chart, one selection must be made from each column only, specifying the row letter.
 eg. Option B. A. E.
 Drive coupling, Brass nuts, Delivery selector and gauge.

When ordering couplings (V), check for availability, state motor frame size and / or engine spigot diameter, shaft and keyway dimensions.

It is recommended that oil expansion bottle 100.290 (Y), is used with the HL pump. Upon request Hi-Low pollution bottle 100.648 (Z) can be fitted to all pumps for added protection.

(TABLE III)
 NB. (C3) Consists of Gauge, adaptor and selector.
 (E3) Consists of Gauge, gauge adaptor, delivery snap coupling & delivery manifold.
 0-6,000 PSI or 0-10,000 PSI Gauge will automatically be suited to pump part number and option selection.

Fig 1.1 Harben 'P' Type High Pressure Pump

SECTION 2

PUMP INSTALLATION

SECTION 2**PUMP INSTALLATION****CONTENTS**

	<u>Para</u>
Introduction	1
Pump Mounting	
General Details	2
Pump Fitting	7
Pump Access	8
Coupling Arrangements	9
Inlet Water	
General	10
Hot Water Conversion Kit	15

ILLUSTRATIONS

<u>Fig</u>		<u>Page</u>
2.1	Pump Installation - Pump Mounting	23
2.2	Pump Installation - Pump Access	24
2.3	Pump Installation - Coupling/Gearbox Arrangements for Diesel Drive	25
2.4	Pump Installation - Coupling Arrangements for Electric Drive	26

PUMP INSTALLATION

INTRODUCTION

1. It may be the case that the pump has not been purchased as part of a trailer or skid. The information given in this section is intended to enable customers to install the pump package in a frame of their design. It will enable engineers to carry out preliminary design work before submitting the design for Flowplant Group approval. Refer to Section 1 for technical data and a description of the pump.

PUMP MOUNTING

General Details

2. The 'P' pumps are designed for direct drive and flange mounting. The normal operating speeds are 1250 rpm for the 'P' pump. Maximum operating speeds are 1250 rpm for the 'P' pump. The pumps can rotate either clockwise or anticlockwise, as required. The maximum inlet water pressure for the pump is 0.5 bar (5.0 metre head), whilst the maximum oil pressure for the pump is 4.0 metre head to centre line of pump.
3. The pump can be inclined between horizontal and 45 degrees (delivery end uppermost). If further inclination is required, between 45 degrees and vertical, Flowplant Group Ltd should be contacted at the address given in Section 1.
4. The weight of a pump with oil in the crankcase, drive coupling fitted and bell housing, depends on the number of cylinders fitted, as follows:

8 cyl - 80 kg	6 cyl - 68 kg
4 cyl - 58 kg	3 cyl - 51 kg
5. The engineer should ensure that all couplings are fitted with a 3 mm clearance. Where a bell housing (pump mounting and coupling shaft and cover) cannot be fitted due to a difference in spigot or bolt locations, an adaptor ring may be fitted.
6. It is recommended that a detailed layout be drawn and the following points considered:
 - a. Selection of bell housing most suitable for adaptor ring. Additional machining to the bell housing may be required.
 - b. Sufficient coupling engagement on the shaft whilst maintaining the recommended clearance.
 - c. Clearance between shafts; careful design can eliminate the shortening of motor/engine shaft. Pump Fitting. (Fig 2.1)

Pump Fittings

7. When the pump is to be fitted in position, the following points should be noted:
- When the pump is first married up to the prime mover, access is required to check coupling clearance. When Flender 8140 couplings are used, sight/gauge holes are drilled in the bell housing for this purpose.
 - Where pumps are fitted with either a pressure gauge or selector (not shown on Fig 2.1) sufficient access must be allowed for sight or operation. If this is impracticable, a remote pressure gauge and selector are recommended.
 - It depends on the particular installation whether the pump head is removed to a workshop for maintenance, e.g. diaphragm or valve replacement or whether work is carried out in-situ. See also Fig 2.2 Note.
 - Where a pump 'strip-down' is required, the pump should be removed to the workshop. The use of an assembly stand is recommended.

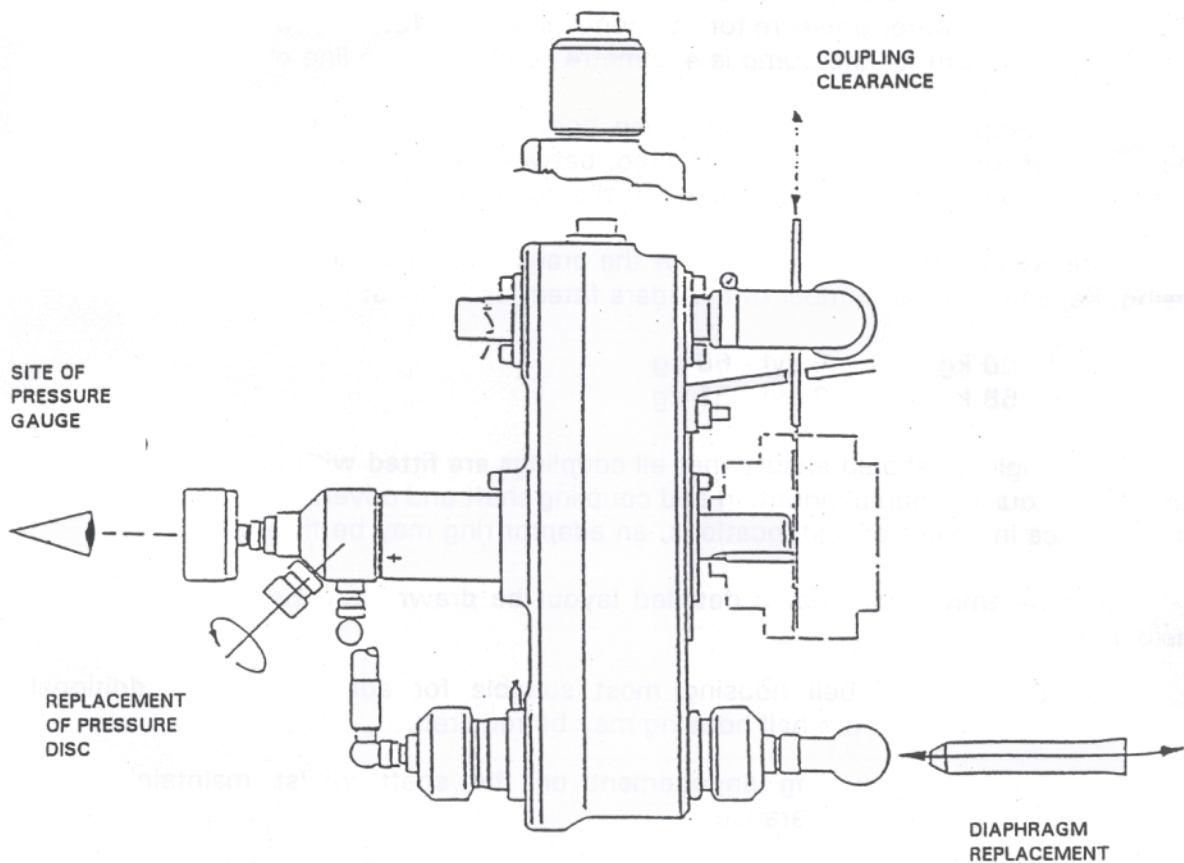
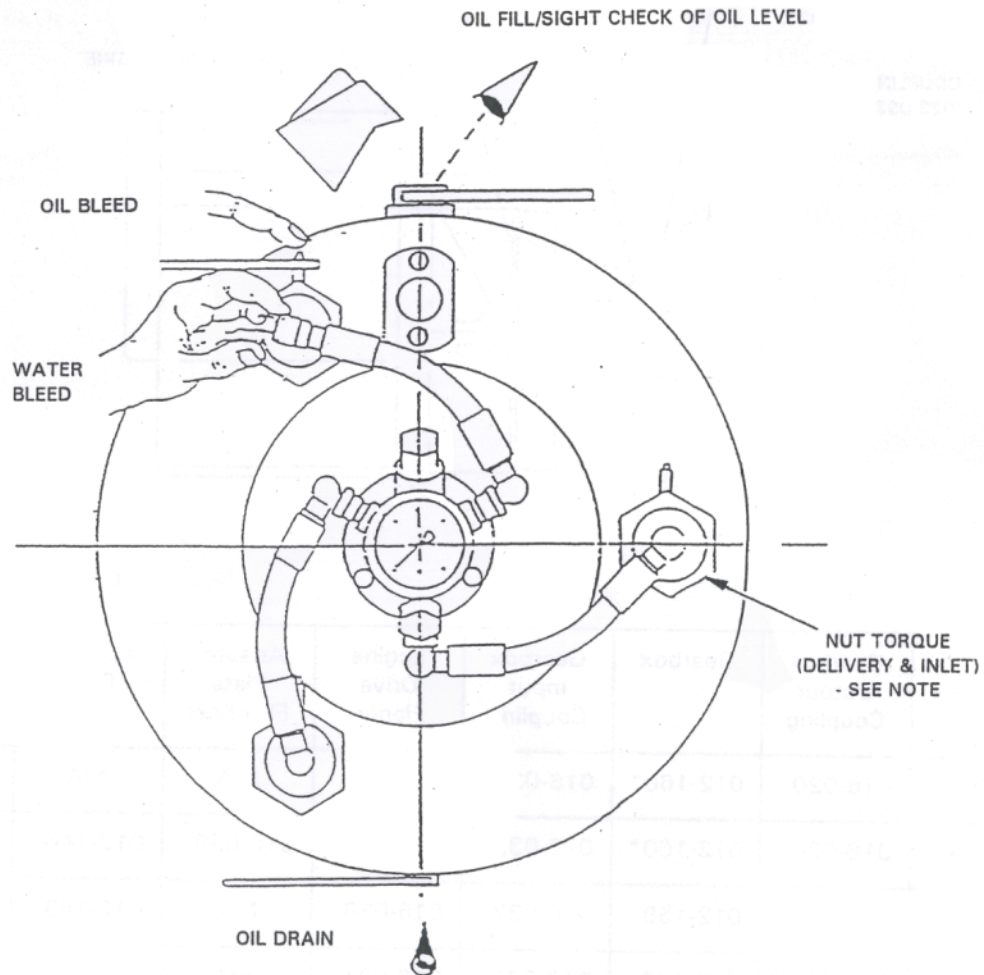

Fig 2.1 Pump Installation – Pump Mounting

Pump Access

8. Reference should be made to Fig 2.2 for the pump access requirements. In addition, access is also required to the pressure disc (Fig 2.1). A withdrawal distance of at least 25 mm should be allowed for removal of the inlet manifold.



NOTE: IT MAY BE NECESSARY FOR THE PUMP HEAD TO BE REMOVED TO CHANGE VALVES AND DIAPHRAGMS. ACCESS IS NOT AVAILABLE ON ALL UNITS FOR THE FITTING OF A SOCKET AND TORQUE WRENCH TO THE INLET NUTS, THUS IF A SOCKET CANNOT BE USED, THEN THE HEAD MUST COME OFF. ON SOME UNITS, UNLESS THE BELL HOUSING IS REMOVED, IT IS IMPOSSIBLE TO FIT A SOCKET.

Fig 2.2 Pump Installation – Pump Access

Coupling Arrangements

9. For details of the engine/gearbox coupling arrangements for diesel-driven pumps refer to Fig 2.3. For details of the coupling arrangements for electrically-driven pumps refer to Fig 2.4.

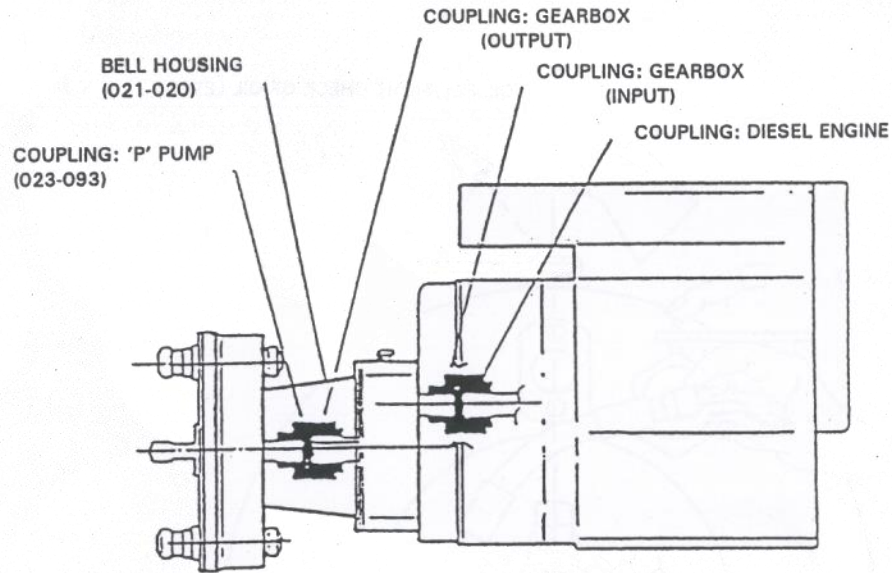

For details on Engine/Motor, Gearbox and pump layouts please refer to the Unit Manual provided.

Fig 2.3 Typical Pump Installation – Coupling/Gearbox Arrangements for Diesel Drive

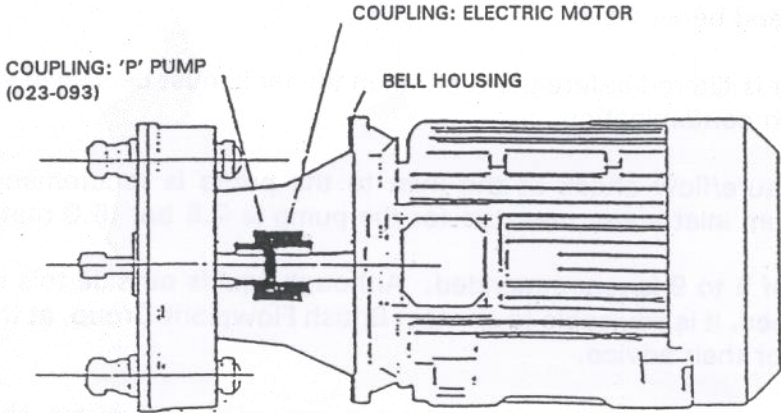

For details on Engine/Motor, Gearbox and pump layouts please refer to the Unit Manual provided.

Fig 2.4 Pump Installation – Coupling Arrangements for Electric Drive

INLET WATER

General

10. It is recommended that inlet water is filtered to between 50 and 177 microns. Flowplant Group offer types of filter suitable for most applications.
11. Turbulent water will cause the pump to run unevenly and cause excessive wear due to cavitations. For this reason, water must first pass through a break water or header tank controlled by a ball valve or float device. Water leaving the tank should have lamina flow characteristics and be air free.

NOTES (1) If water is filtered before the tank, then the tank must be sealed and vented to avoid contamination.

(2) A pressure/flow check at the inlet to the pump is recommended. The maximum inlet water pressure for the pump is 0.5 bar (5.0 metre head).

12. A pH value of 5 to 9 is recommended. Although liquids outside this range may occasionally be pumped, it is advisable to contact Flowplant Group, at the address given in Section 1, for their advice.
13. Hose and pipe bores between the break water tank and pump should be a minimum of 32 mm (1 ¼in) and up to a length of 1 metre. If a longer length of hose/pipe is required, refer to the nearest authorised dealer.
14. Other points to be considered concerning inlet water are:
 - a. Avoid long hose or pipe runs.
 - b. Avoid hose or pipe runs that cause air pockets.
 - c. Refer to circuit layout for mounting angle of pump.
 - d. If water inlet temperature is over 25°C, consult the nearest authorised dealer (unless 70°C Hot Water Conversion Kit is fitted - see Para 15).

Hot Water Conversion Kit

15. A Hot Water Harben 'P' Pump Conversion Kit (Part No. 009-001) is available to enable hot water, up to 70°C, to be used with the pump.

16. A conversion kit is available for each barrel. The number of conversion kits required equals the number of barrels in the pump supplied. The conversion kit comprises the following items:

Per Barrel	Part No.	Qty
CASTING MANDREL P TYPE HIGH TEMP WATER INLET	009-002	1
VALVE INLET FOR HIGH TEMP WATER INLET	009-004	1
VALVE DELIVERY HIGH TEMP WATER INLET	009-005	1
BARREL O-RING VITON BS135/60 P-TYPE	009-008	2
O-RING END PLATE VITON "103"70 SHORE 1150MM LG VIT	009-009	1
O-RING CENTER VITON BS036/70	009-010	2
O-RING COOLER VITON BS122/70	009-011	2
Per pump	Part No.	Qty
HOT WATER PUMPING P-PUMP 'O' RING KIT	009-016	1
KIT - HOT WATER CONVERSION - 8 CYL P TYPE PUMPS	009-102	1
KIT - HOT WATER CONVERSION - 6 CYL P TYPE PUMPS	009-103	1
KIT - HOT WATER CONVERSION - 4 CYL P TYPE PUMPS	009-104	1
KIT - HOT WATER CONVERSION - 3 CYL P TYPE PUMPS	009-105	1

17. Depending on the water hardness, it may be necessary to install an industrial descaler in the water tank to prevent a build-up of scale.
18. One point to consider when converting a pump, and subsequently working out a maintenance program, is that pump bearing life will be significantly reduced. This will need to be considered in the maintenance program.

Large Bearing Conversion Kit

19. A Large bearing Harben 'P' Pump Conversion Kit (Part No. 700-1919) is available, see parts list below.

Per Pump	Part No.	Qty
CYLINDRICAL ROLLER BEARINGS C-TXT LOCATING	017-113	1
CYLINDRICAL ROLLER BEARINGS C-TXT FLOATING	017-114	1
SCREW SET HEX HD M 8-1.25 6G 50 LG HT 8.8 ZN	023-067	3
KEY 8 x 7 x 53MM INTERNAL ECCENTRIC (LARGE BEARINGS)	078-1014	1
MODIFICATION TO COUNTER BALANCE (P TYPE)	078-941	2
BEARING RETAINER (LARGE BEARINGS)	078-943	2

SECTION 3

GENERAL OPERATING INFORMATION

SECTION 3**GENERAL OPERATING
INFORMATION****CONTENTS**

	<u>Para</u>
Introduction	1
Safety Code of Practice	2
General	5
Safety Gun	6
Drain/Sewer and Pipe Cleaning	7
Hoses	8
Underwater Recoil-less Safety Gun	9
Tube Cleaning	10
Hoverclean	11
Abrasive Injection Equipment	12
Accidents	13
Protective Equipment	14
General Operating Instructions	
Introduction	15
Starting	16
Stopping	17
To Oil Bleed the Pump	18
To Water Bleed the Pump	19
To Anti-Freeze a Unit Without an Anti-Freeze Tank	20
To Remove Anti-Freeze From a Unit Without an Anti-Freeze Tank	21
To Anti-Freeze a Unit With an Anti-Freeze Tank Fitted	22
To Remove Anti-Freeze From a Unit With an Anti-Freeze Tank Fitted	23
Fault Finding	
General	24

ILLUSTRATIONS

<u>Fig</u>		<u>Page</u>
3.1	Bleeding the Pump	36
3.2	Pump Fault Finding - Diaphragm Failure	41

TABLES

<u>Table</u>		<u>Page</u>
3.1	Equipment Fault Finding	39-40
3.2	Pump Fault Finding	42

GENERAL OPERATING INFORMATION

INTRODUCTION

1. This section gives general information on safety, protective clothing to be used by operators, and general starting and stopping procedures when the pump is incorporated in equipment. It should be remembered that the operating procedures given are to be used as a guide only and the equipment handbook operating procedures should be used where applicable.

SAFETY CODE OF PRACTICE

BASIC RULES

1. ALWAYS WEAR THE CORRECT PROTECTIVE CLOTHING.
 2. ALWAYS ENSURE ALL EQUIPMENT IS IN A FIRST CLASS CONDITION,
 3. NEVER WORK FROM A LADDER.
 4. NEVER USE THE GUN WITH THE TRIGGER LOCKED ON.
 5. NEVER POINT THE GUN AT ANYONE, EVEN IF SWITCHED OFF.
2. This Code of Practice is intended to provide guidance on the safe operation of high pressure water jetting equipment.
 3. The term 'high pressure water jetting' covers all water jetting, including the use of additives and abrasives, where there is an energy input to increase the pressure of water.
 4. This code applies to high pressure water jetting as defined above where there is a foreseeable risk of injury.

General

5. (1) Only a responsible person who has received instruction in the operation of high pressure water jetting equipment should be allowed to operate the equipment.
- (2) Barriers should be erected around the cleaning bay or where the work is being done 'in-situ', round the section of plant concerned. Access within 10 metres by persons other than the jetting team, is strictly prohibited.
- (3) A warning notice 'NO UNAUTHORISED ENTRY High Pressure Water Jetting in Progress' should be displayed on each side of the bay, or on the plant, where the work is to be done.
- (4) Each member of the team should be provided with suitable waterproof clothing, wellington boots with internal steel toe caps, safety helmet with visor and earmuffs, and gloves. Refer to Para 14 for details of protective clothing available.

SAFETY CODE OF PRACTICE (Cont'd)

General (Cont'd)

- (5) Never attempt to change jets or accessories whilst the pump is operating, even if the flow control selector valve is in the recycle (dump) position.

Safety Gun

6. (1) Never point the safety gun at anyone, even if it is switched off.
- (2) When using the 'deadman's handle' safety gun, the required jet should be fitted to the high pressure barrel (low pressure barrel is fitted with a diffuser) and tightened correctly before starting the unit. All other hose connections, etc must be checked before attempting to start the unit.
- (3) Water jetting guns should be properly maintained and care should be taken not to damage the delicate components of the trigger mechanism.

Drain/Sewer and Pipe Cleaning

7. (1) In addition to the protective clothing listed in Para 5(4), the other equipment should be used when entering confined spaces, such as safety harness and rescue line, atmospheric testing equipment, escape breathing apparatus and hand lamps (intrinsically safe where appropriate).
- (2) To prevent snaking or reverse travel of a flexible hose inside the tube being cleaned, a section of steel pipe, slightly longer than the diameter of the tube to be cleaned, should be connected between the flexible hose and the nozzle (drain jet extension).
- (3) During drain cleaning operations it is advisable to use a coloured leader hose to act as a warning to the operator that the hose recovery is almost complete.
- (4) Where drain or pipe jetting operations are to be carried out remote from the high pressure pump unit, i.e. where communication between the person controlling the pump and the equipment operator is not possible, it is essential that a remote control kit or foot control valve is used at the work point.

Hoses

8. (1) Care should be taken to ensure that all hoses are maintained in good condition and are of the correct specification for the pressure being used.
- (2) Never loop the hose into an excessively tight radius, particularly adjacent to couplings.
- (3) When fitting re-usable couplings, always ensure that the correct type of couplings are being used in relation to the hose specification.

SAFETY CODE OF PRACTICE (Cont'd)

NOTE The equipment detailed in Para's 9, 10, 11 and 12 are for specialist applications.

Underwater Recoil-less Safety Gun

9. (1) The Harben Underwater Recoil-less Safety Gun is designed for use under water only. Extreme care should be taken to avoid rear-facing balance jets when testing the equipment above water.
- (2) If working in shallow water, where there is a possibility of the diver surfacing inadvertently during water blasting, care should be taken to ensure that the recoil balance jet protection tube is sufficiently long to prevent the diver directing it at himself.

Tube Cleaning

10. (1) Where tube cleaning is to be done by means of a lance, the charge-hand who operates the remote control valve should first insert the lance into the tube, leaving the other end of the lance supported by one man. Once the tube has been inserted, the other men required to support the control lance should take up their places, and only then should the charge-hand operate the valve.

NOTE When the person operating the remote control valve is unable to speak directly to the man, or men, controlling the lance, a clearly understood system of signals and instructions must be agreed upon.

- (2) A barrier should be placed at the far end of the tube being cleaned for protection against flying debris.
- (3) A shield fitted to the lance to protect the operator from debris ejected by backward pointing jets should be used for certain operations.

Hoverclean

11. (1) The angle of the jet holders determine the rotational speed of the spray bar; this is set and locked in position at the works, and on no account must this angle be altered.

Abrasive Injection Equipment

12. (1) Because water/abrasive jetting can give rise to dangerous splash back, ensure all protective clothing, detailed in Para 5(4), is used. Some abrasives are known to produce residues which may be hazardous to health and should not be used for blasting, such as sand containing free silica.

Accidents

13. (1) In the event of a person being injured by the impact of a water jet, the injury caused may appear insignificant and give little indication of the extent of the injury beneath the skin and the damage to deeper tissues. Large quantities of water may have punctured the skin, flesh and organs through a very small hole that may not even bleed.

SAFETY CODE OF PRACTICE (Cont'd)**Accidents (Cont'd)**

(2) Operators should carry a card which explains to medical staff the possible nature of the injury, both relating to the high pressure water and any unusual infections that may be found in sewage, such as Leptospirosis, better known as Weirs Disease.

PROTECTIVE EQUIPMENT

14. A range of top quality protective equipment is available from Flowplant Group Ltd, as follows:

Part Number	Description
061-037	Suit Waterproof Coverall - size small
061-025	Suit Waterproof Coverall - size medium
061-026	Suit Waterproof Coverall - size large
061-020	Suit Waterproof Coverall - size extra large
065-076	Metatarsal Safety Boots – size 6
065-061	Metatarsal Safety Boots – size 7
065-060	Metatarsal Safety Boots – size 8
065-057	Metatarsal Safety Boots – size 9
065-058	Metatarsal Safety Boots – size 10
065-066	Metatarsal Safety Boots – size 11
065-065	Metatarsal Safety Boots – size 12
065-062	Gauntlet Gloves
065-013	Complete Helmet Set
061-054	'No Unauthorized Entry – High Pressure Jetting In Progress' Safety Sign
061-225	Operators Safety Guide
057-062	Safety Code of Practice
061-445	Code of Practice (Sewer Drain Jetting)
061-259	Guide Do and Don't Booklet

GENERAL OPERATING INSTRUCTIONS

Introduction

15. The following operating instructions are of a general nature with reference being made to the appropriate manufacturer's handbook for the machine. The machine should be in the shut down position.

Starting

16. To start the unit, carry out the following instructions:

- (1) Prior to starting the unit, carry out the following pre-checks:

- i. Set the high pressure selector to the recycle (dump) position.
- ii. Ensure engine/motor is switched off.
- iii. Ensure the unit is on level ground.
- iv. Check that the water supply is connected and the header tank is full.
- v. Check that all guns and nozzles are connected. Ensure correct fitting and correct size for the pressure required.

- (2) Start the unit. Refer to the manufacturer's handbook for information concerning engine/electric motor starting procedure.

NOTE Before starting the unit and carrying out water and/or oil bleed operations (refer to Para's 18 and 19, respectively), familiarise yourself with the unit's controls and the stopping instructions (Para 17).

- (3) Move the selector to the High Pressure position.

Stopping

17. To shut down the unit, carry out the following instructions:

- (1) Reduce engine revs to tick-over speed.
- (2) Move the high pressure selector to the recycle (dump) position.
- (3) Switch off the prime mover by following the instructions given in the manufacturer's handbook for the engine/electric motor.
- (4) If there is the risk of freezing, follow the instructions given the frost precautions (anti-freeze procedures, Para's 20 or 22).
- (5) If the unit is to be stored for more than 7 days without running, an inhibitor should be

run through the system. Do not drain prior to storage; always leave full of fresh water or inhibitor.

(6) Refer to the manufacturer's handbook for information concerning engine/ electric motor protection/storage.

To Oil Bleed the Pump

18. As delivered from the factory, the pump would have already been oil bled (except pump heads supplied separately). If necessary, oil bleed the pump as follows:

NOTE Refer to the lubrication chart given in Section 4, Table 4.2 for details of pump oil types and capacities.

(1) Fill the pump to the top of the crankcase with the correct oil; the top of the oil cooler should just be visible (or ensure oil is in the expansion bottle, if fitted). To identify the oil cooler, refer to Item 11 on the drawings located Section 4.

(2) Set the selector valve to the recycle (dump) position and start the engine/ motor. Run at 750 rpm tick-over to prime, or inch electric motor (on/off).

NOTE If the unit is fitted with a shut-down protection device, hold in the override button for 10 seconds (this allows the engine oil pressure to build up).

(3) With reference to Fig 3.1, put a finger on top of an oil bleed screw on a lower barrel and open the screw slowly using a suitable spanner. When air-free oil flows, tighten the bleed screw firmly.

NOTE Top up oil in the pump crankcase after each barrel has been bled.

(4) Repeat the procedure detailed in sub-pars (3) for each barrel, starting from the lower barrels first.

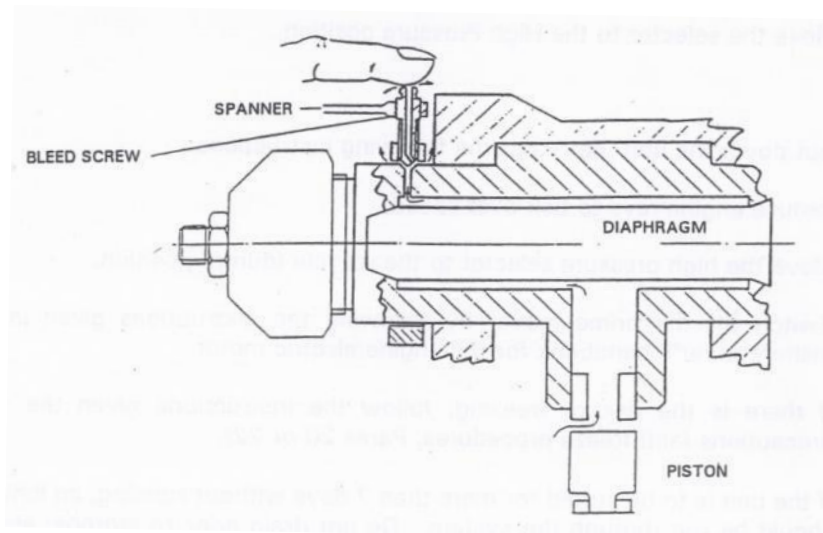

Fig 3.1 Bleeding the Pump

(5) When the operator has taken up a working position, move the selector lever to the High Pressure position and increase engine speed to reach working pressure.

(6) If the delivery line vibrates or the pump does not run smoothly, stop the unit and carry out a water bleed (Para 19) and then repeat the oil bleed.

To Water Bleed the Pump

CAUTION ON NO ACCOUNT OPEN THE WATER BLEED SCREWS WHEN THE PUMP IS OPERATING UNDER PRESSURE.

19. Whenever the unit is started after being allowed to run dry, the following procedure must be followed:

(1) Set the selector valve to the recycle (dump) position and start the engine/ motor. Run at 750 rpm tick-over to prime, or inch electric motor (on/off).

NOTE If the unit is fitted with a shut-down protection device, hold in the override button for 10 seconds (allows engine oil pressure to build up).

(2) The pump is self-priming. If, however, any difficulty is experienced, stop engine, loosen the upper bleed nipples and allow water to flow from each nipple (ensure that the header tank remains full). Tighten nipples and repeat the procedure detailed in sub-pars (1). To identify the bleed nipples, refer to Item 72 on the drawings located Section 4.

(3) When the operator has taken up a working position, move the selector lever to the High Pressure position and increase engine speed to reach working pressure.

NOTE If the delivery line vibrates this indicates that air is still in the system. Stop the unit and repeat the procedure detailed in sub-pars (1).

To Anti-Freeze a Unit without an Anti-Freeze Tank

20. (1) Prepare 5 gallons (or larger quantity if required) of 30% to 50% anti-freeze solution.

(2) Drain the water tanks.

(3) Pour the anti-freeze solution into the break tanks.

(4) Remove any jet or accessory from the end of the high pressure hose.

(5) Ensure the high pressure selector lever is in the dump (or off) position. Start the engine and allow to run for 1 minute,

(6) Holding the outlet end of the hose, move the selector to high pressure position and allow the engine to run until the anti-freeze solution can be seen coming from the high pressure hose.

(7) Stop the engine. –The unit is now anti-frozen.

To Remove Anti-Freeze From a Unit without an Anti-Freeze Tank

NOTE During this procedure, carry out the air bleed procedure detailed in Para 19, if necessary.

21. (1) Drain any anti-freeze solution from break tanks into a container.
- (2) Fill break tanks with water,
- (3) Place the outlet of the high pressure hose into the container.
- (4) Place the selector lever in the high pressure position, and whilst holding the high pressure hose, start the engine.
- (5) Run the engine until all solution is returned to the container and clean water is seen flowing from the hose. The unit is now ready to use.

To Anti-Freeze a Unit with an Anti-freeze Tank Fitted

22. (1) Ensure the anti-freeze tank is full of 30% to 50% anti-freeze solution.
- (2) Turn the 3-port valve to the anti-freeze position and open valve on the anti-freeze tank (if fitted).
- (3) Remove any jet or accessory from the end of the high pressure hose.
- (4) Move the selector lever to the high pressure (or on) position.
- (5) Holding the end of the hose, start the engine.
- (6) Allow engine to run on tick-over until the anti-freeze solution can be seen coming from the high pressure hose.
- (7) Move the selector to the recycle (dump) position for 5 seconds (this allows the dump hose to be anti-frozen).
- (8) If Jump Jet or Remote Control kits are fitted, ensure they are anti-frozen. The unit is now anti-frozen.

To Remove Anti-Freeze from a Unit with an Anti-freeze Tank Fitted

23. (1) Move the 3-port valve to the water position.
- (2) Fill the water tanks.
- (3) Place the outlet of the high pressure hose into the anti-freeze tank.
- (4) Place the selector lever in the high pressure position.
- (5) Start the engine. Allow it to run at tick-over and pump anti-freeze solution into the anti-freeze tank. Stop the engine when clear water is seen flowing out of the high pressure hose. The unit is now ready to use.

FAULT FINDING**General**

24. It is essential when fault finding on the pump that due regard is taken of the likely equipment faults. Therefore, Table 3.1 includes likely equipment faults, whilst Table 3.2 gives likely pump faults. For details of engine faults refer to the appropriate manufacturer's handbook. When investigating a pump diaphragm for possible failure, refer to Fig 3.2.

Table 3.1 Equipment Fault Finding

Problem	Cause	Action
Low System Pressure	<ol style="list-style-type: none"> 1. Worn or incorrect size of cutting nozzle. 2. Engine speed slow. 3. Leaks from hose, pipes and connections. 4. Blocked inlet filter. 5. Inlet hose too long. 6. Loss of water through dump line of selector valve or gun when high pressure selected. 7. Loss of water through dump line of remote control kit, if fitted. 	<p>Replace nozzle.</p> <p>Adjust to correct speed.</p> <p>Check connections for tightness. Replace as necessary.</p> <p>Clean or replace element.</p> <p>Shorten hose length.</p> <p>Check seats and seals.</p> <p>Check seats and seals.</p>
High System Pressure	<ol style="list-style-type: none"> 1. Blocked nozzle, selector valve or gun. 2. Incorrect nozzle size. 3. Incorrect bore size. 4. Engine speed high. 5. Crushed delivery hose. 6. Two gun choke left in gun when operating as single gun unit. 	<p>Clean nozzle, selector valve of gun and flush out delivery line.</p> <p>Replace nozzle.</p> <p>Replace nozzle.</p> <p>Adjust to correct speed.</p> <p>Replace if necessary.</p> <p>Replace with standard choke.</p>

Table 3.1 Equipment Fault Finding (Cont'd)

Problem	Cause	Action
Low Water Level	<ol style="list-style-type: none"> 1. Blocked or dirty pre-filters. 2. Faulty ball valve assembly. 3. Wrong seat in ball valve assembly. 4. Low inlet pressure 	<p>Clean or replace elements.</p> <p>Replace if necessary.</p> <p>Replace if necessary.</p> <p>Increase pressure.</p>
Pump Not Running Evenly (also refer to Pump faults).	<ol style="list-style-type: none"> 1. Air in water. 2. Air in crankcase oil. 3. Worn Coupling 4. Faulty inlet or delivery valve. 5. Valve nut over tightened. 	<p>Water bleed pump (Para 19)</p> <p>Oil bleed pump (Para 18)</p> <p>Replace flexible elements and examine coupling.</p> <p>Check valve condition.</p> <p>Check tightness of inlet and delivery nut.</p>
Burst Disc Failure or Safety Relief Valve Operating (also refer to high system pressure problem).	<ol style="list-style-type: none"> 1. Incorrect burst disc. 2. Incorrect valve setting. 3. Faulty Valve. 4. Faulty or fatigued burst disc. 	<p>Replace with correct disc.</p> <p>Check certificate/setting.</p> <p>Repair or replace, as necessary.</p> <p>Replace with new disc.</p>

Table 3.2 Pump Fault Finding

Problem	Cause	Action
<ol style="list-style-type: none"> 1. Mixing of Oil and Water in Crankcase. 2. Loss of pressure. 3. Pump not running evenly. 	<ol style="list-style-type: none"> 1. Worn or damaged delivery valves. 2. Damaged filter element allowing debris to jam delivery valve. 	<ol style="list-style-type: none"> 1. Check all delivery valves – replace as necessary. 2. Check all diaphragms – replace as necessary. 3. Replace oil. 4. Check filters – replace as necessary.
<ol style="list-style-type: none"> 1. Loss of crankcase oil through high pressure hose. 2. Loss of pump pressure 3. Pump not running evenly 	<ol style="list-style-type: none"> 1. Inlet restriction may have been caused through; <ol style="list-style-type: none"> a. Blocked filters b. Kinked inlet hose c. Worn or damaged inlet valves d. Excessive inlet hose length 2. Pump has been frozen 	<ol style="list-style-type: none"> 1. Clear restriction. 2. Check inlet valves – replace as necessary. 3. Check diaphragms – replace as necessary. 4. Replenish oil.
<ol style="list-style-type: none"> 1. Mixing of Oil and Water in Crankcase. 	<ol style="list-style-type: none"> 1. Diaphragm failure (may have been through fatigue from excessive running hours). 	<ol style="list-style-type: none"> 1. Check all diaphragms – replace as necessary.

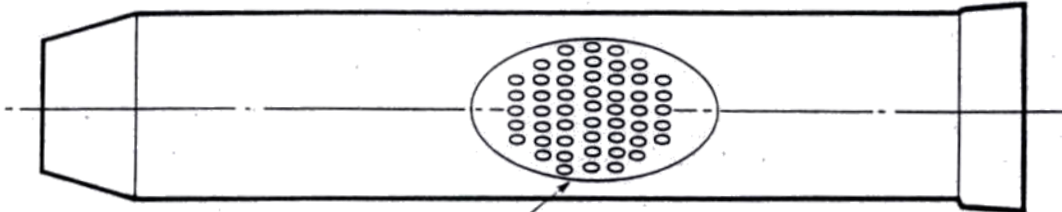

Impression of baffle on diaphragm (Reason – being inflated).

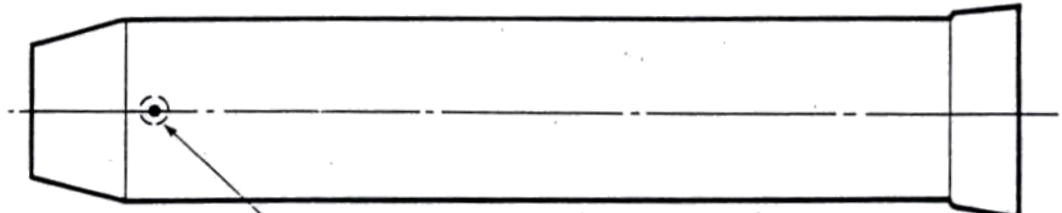

4 small impressions similar to illustration (Reason – diaphragm pumping through mandrel delivery holes).

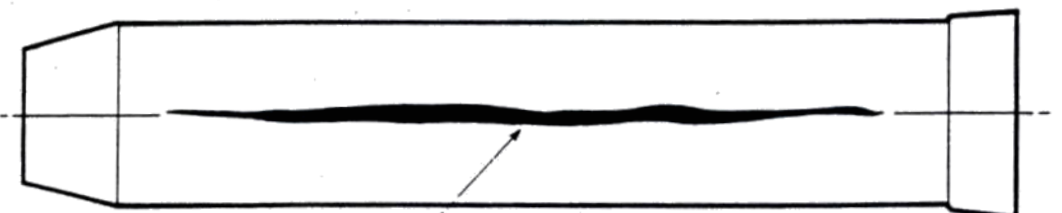

Shear through wall of diaphragm

Fig 3.2 Pump Fault Finding – Diaphragm Failure

SECTION 4
PUMP MAINTENANCE
AND
OVERHAUL PROCEDURES

SECTION 4
PUMP MAINTENANCE
AND
OVERHAUL PROCEDURES
CONTENTS

	<u>Para</u>
Routine Maintenance	
Introduction	1
Pump Service Information	
General	3
Recommended Service Tools	4
Torque Settings	5
Burst Discs	6
Service Kits	7
Pump Overhaul Procedures	
Introduction	8
Removal and Replacement of Pump Head	10
Removal and Replacement of Diaphragms and Valves	11
Pump Strip and Re-Assembly	13
Pump Running In	15

ILLUSTRATIONS

<u>Fig</u>		<u>Page</u>
4.1	Inlet Valve Identification	51
4.2	Pump Cylinder Code	54
4.3	'P' Type Pump - Pump Assembly	56
4.4	'P' Type Pump - Barrel Assembly	57
4.5	'P' Type Pump - Pump Cross-Section	58
4.6	'P' Type Pump - Pump Parts List	59
4.7	'P' Type Pump - Inlet Manifold Assembly	60
4.8	Manifold Selector Assembly	61
4.9(a)	Inline Selector Assembly	62
4.9(b)	Inline Selector Assembly	63

TABLES

<u>Table</u>		<u>Page</u>
4.1	Pump Maintenance Schedule	45
4.2	Pump Lubrication Chart	46

PUMP MAINTENANCE AND OVERHAUL PROCEDURES

ROUTINE MAINTENANCE

Introduction

1. The Maintenance Schedule (Table 4.1) gives details of pump maintenance only.

For details of equipment maintenance, refer to the appropriate handbook. Details of pump oil capacities and recommended oil types are given in the Lubrication Chart (Table 4.2). Refer to the manufacturer's handbook for diesel engine oil.

2. Whilst specific periods for routine (preventive) maintenance of the pump are given, due regard should be taken of local regulations concerning the vehicle or machine. Ensure the machine is operating within those regulations.

Table 4.1 Pump Maintenance Schedule

CHECKLIST	PRIOR TO USE/DAILY/AFTER 8 HOURS RUNNING
Crankcase oil	Check for level, fill if necessary (refer to Section 3, Para 18(1) for procedure and Table 4.2 for oil types).
Pipes, hoses and fittings	Check wear, damage, correct rating and size.
Pump working pressure	Check correct.
General	Check pump for smooth running, overheating, leaks and security of components.
SIX MONTHLY/300 HOURS	
Inlet/delivery valves	Check for wear and damage
Diaphragms	Check for wear and damage
YEARLY/500 HOURS	
Crankcase oil	Drain and renew.
Inlet/delivery valves ('P')	Check for wear and damage.
Inlet/delivery valves ('HL')	Replace.
Pipes, hoses and fittings	Carry out a detailed inspection.
TWO YEARLY/1000 HOURS	
Inlet/delivery valves ('P')	Replace.
Diaphragms	Replace.

Table 4.2 Pump Lubrication Chart

Manufacturer	Type	Oil Capacity (litres)			
		Number of Cylinders			
		3-Cyl	4-Cyl	6-Cyl	8-Cyl
ESSO	Nuto H150	6.5	6	5.75	5
GULF	LP 150				
MOBIL	DTE Extra Heavy				
ROC	Kiron				
TEXACO	Rando HD 150				
BP	Energol HLP 150				
AGIP	OSO 105				
SHELL	Morlina 150				
CENTURY OIL	PWLM				
PETROFINA	Hydran 51				
CASTROL	Hyspin AWS 150				

PUMP SERVICE INFORMATION

General

- The following paragraphs give details of recommended service tools, torque settings, burst discs and service kits to be used when carrying out pump overhaul procedures.

Recommended Service Tools

- The following tools should be available when servicing the pump:

Description	Part Number
Repair stand	042-177
Spanner, open ended, 9/16" whit. x 5/8" whit.	202-048
Spanner, open ended, 19 mm	202-036
Spanner, open ended, 1 3/8" whit.	202-037
Spanner, adjustable, 12"	202-302
Spanner, combination, 4 BA	202-150
Pipe grips	206-102
Hammer, nylon. 1 3/4" dia.	206-001
Allen key, 6 mm	206-103
Pliers, circlip, external, 10-25 mm	205-001
Wrench, 'T' hex, 4 mm	204-002
Screwdriver, flat blade, 10"	206-101
Torque wrench	203-256
Socket, reversible ratchet, 1/2" square drive	203-242
Socket, extension bar 250 mm, 1/2" square drive	203-247
Socket, 1/2" square drive, 11116"	203-129
Socket, 1/2" square drive, 17 mm	203-170
Drift, mandrel	061-044
Dolly, bearing	201-007
Set screws, M8 x 50 mm (6 off)	023-067

Torque Settings

5. The torque settings for selected components are:

	Drg Item No*	lbft	kgm	Nm
Nut, nyloc, M20 x 1.5	29	100	13.8	135
Valve nut, delivery	44	80	11.1	109
Valve nut, inlet	41	80	11.1	109
Adaptor	49	30	4.1	41
Adaptor	73	29	4.0	39
Set screw	20	20	2.8	27
Set screw	14	40	5.5	54
Holder for Burst Disc	64	25	3.5	34
Banjo bolt	R3	118	16.3	160

* Refer to Para 9 and the drawings in this section to locate Item Number.

Burst Discs

6. When carrying out any maintenance/overhaul of the pump, ensure the correct burst disc, for its working pressure, is fitted. The available burst discs are as follows:

Colour Code	Part Number	For Maximum Working Pressure
Yellow	011-019	125 bar (1800 psi)
Blue	011-020	140 bar (2000 psi)
Red	011-021	175 bar (2500 psi)
Purple	011-022	210 bar (3000 psi)
Green	011-045	240 bar (3500 psi)
White	011-046	275 bar (4000 psi)
Black	011-047	345 bar (5000 psi)
Orange	011-107	415 bar (6000 psi)

Service Kits (Kits not available in all countries)

7. Service/overhaul kits are available when carrying out repair or overhaul of the pump. Details of kits for the Standard 'P' pump are as follows:

a. Standard 'P' Pump Service Kit

Kit overhaul, valve and diaphragm, 3-cyl 'P' pump	Part No 023-236
Kit overhaul, valve and diaphragm, 4-cyl 'P' pump	Part No 023-237
Kit overhaul, valve and diaphragm, 6-cyl 'P' pump	Part No 023-238
Kit overhaul, valve and diaphragm, 8-cyl 'P' pump	Part No 023-239

<u>Part No</u>	<u>Description</u>	<u>Quantity</u>			
		3-cyl	4-cyl	6-cyl	8-cyl
011-060	Valve, delivery	3	4	6	8
011-048	Valve, inlet	3	4	6	8
012-032	Diaphragm	3	4	6	8

b. Hot Water Conversion

HOT WATER PUMPING P-PUMP 'O' RING KIT	Part No 009-016
KIT - HOT WATER CONVERSION - 8 CYL P TYPE PUMPS	Part No 009-102
KIT - HOT WATER CONVERSION - 6 CYL P TYPE PUMPS	Part No 009-103
KIT - HOT WATER CONVERSION - 4 CYL P TYPE PUMPS	Part No 009-104
KIT - HOT WATER CONVERSION - 3 CYL P TYPE PUMPS	Part No 009-105

c. Large Bearing Conversion

CONVERSION KIT LARGE BEARINGS P TYPE PUMP	Part No 700-1919
---	------------------

PUMP OVERHAUL PROCEDURES

Introduction

8. During the pump overhaul procedures, reference should be made to the pump assembly drawings, including associated Parts List, located at the rear of this section. Also included are assembly drawings of the inlet manifold and inline and manifold selectors.
9. In the following overhaul procedures, the item number that follows the description of a part refers to the assembly drawings (Figs 4.3 to 4.6). Where the letter M appears before the item number, refer to the Inlet Manifold Assembly drawing (Fig 4.7). Where the letter R appears before the item number, refer to the Manifold Delivery Assembly drawings (Figs 4.8 and 4.9).

Removal and Replacement of Pump Head

NOTE Refer to Para 9 for drawing information.

10. Carry out a removal and replacement of the Pump Head, as follows:
 - (1) Switch off and isolate the prime mover.
 - (2) Switch off or disconnect the water mains supply to the tank.
 - (3) Drain the water tank.
 - (4) Disconnect the water inlet hose to the pump.
 - (5) Disconnect the high pressure hose from the Delivery Manifold or Selector, as fitted.
 - (8) Drain water from the base of the Inlet Manifold (12). Replace when drained.
 - (7) Disconnect the hose Snap Coupling from the top of the Crankcase to oil expansion bottle, if fitted.
 - (8) Remove either the Expansion Chamber (4) or the Adaptor from the top of the Crankcase, and replace with a Lifting Eye (Part No 061-077).
 - (9) Connect lifting tackle to the Lifting Eye. Do not take the weight of the pump, leave only slack cable.
 - (10) Remove the bolts from the bell housing and pull off pump and bell housing.
- NOTE** If an adaptor ring is fitted, it is usually best to leave it attached to the prime mover.
- (11) Before replacing the pump, check the drive coupling stand-off distance.

- (12) Replace the pump, generally reversing the removal procedure.

NOTE Before operating the pump, it may be necessary to bleed the pump of air.

- (13) If the pump fitted is new or has been overhauled, carry out the running in procedure detailed from Para 15.

Removal and Replacement of Diaphragms and Valves

NOTES (1) In most cases the work can be carried out on the machine.

- (2) Refer to Para 9 for drawing information.

11. Carry out removal of Diaphragms and Valves, as follows:

- (1) On the Standard Delivery Manifold uncouple the Top Hose (70 and 71) from Adaptor (49).
- (2) the Inlet Manifold (12), by drawing back the Retaining Ring (M2), opening the Spring Clip (M4) and pulling the Inlet Manifold evenly off Valve Nuts (41) and Cooler (1 1).
- (3) Unscrew the Valve Nut (41) two turns if the Delivery Valve (43) only is to be removed. If Diaphragm (51) and Inlet Valve (45 or 46) are to be removed, then unscrew the Valve Nut (41) completely.
- (4) Remove Valve Nut (44) completely.
- (5) If Diaphragms (51) are to be removed, drain the oil from the pump.
- (6) Remove a Diaphragm (51), Mandrel (52) and Inlet Valve (45 or 46 - refer to Fig 4.1) by placing a drift (Part No 061-044) in the end of the Mandrel at the delivery end of the Barrel and tapping the drift gently with a mallet.
- (7) Remove the Delivery Valve (43) carefully using pipe grips (Part No 206-102).

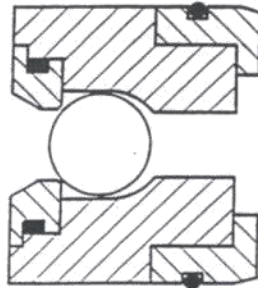

INLET VALVE FOR P PUMP

PART No 011-048 (ITEM 46)

MAX PRESSURE 415 BAR

MAX 1250RPM

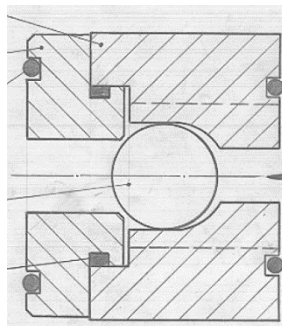

DELIVERY VALVE FOR P PUMP

PART No 011-060 (ITEM 43)

MAX PRESSURE 415 BAR

MAX 1250RPM

Fig 4.1 Inlet & Delivery Valve Identification

12. Carry out re-assembly of the Diaphragms and valves, as follows:

NOTE On no account should Diaphragm (51) and Mandrel (52) be fitted as an assembly. If the Delivery Valve (43) is removed for any reason, or the delivery Valve Nut (44) is slackened, the inlet Valve Nut (41) must be slackened off two turns and the delivery Valve Nut (44) tightened before the inlet, Valve Nut (41) is retightened.

- (1) Assemble Valves (43 and 45 or 46). Ensure components are clean and all 'O' rings are undamaged.
- (2) Ensure that the tapers in the Barrels are clean and dry.
- (3) Lubricate the external tapers of the Diaphragm with pump oil and insert the Diaphragm into the Barrel, from the pump side.
- (4) Fit the Delivery Valve assembly (43). Confirm that it is a Delivery Valve and that it is fitted correctly.
- (5) Replace Valve Nut (44) and torque it to 109 Nm.
- (6) Lubricate Mandrel (52) with pump oil, and push the Mandrel as far as possible into the Diaphragm (51).
- (7) Fit Inlet Valve assembly (45 or 46). Confirm that it is an Inlet Valve and that it is fitted correctly. Grease the outside of the Inlet Valve to ease assembly.
- (8) Replace Valve Nut (41) and fully tighten. Where access is possible, use a socket and torque wrench and torque the Valve Nut to 109 Nm.
- (9) The pump will now require oil bleeding in accordance with the procedure detailed in Section 3, Para 18.

Pump Strip and Re-Assembly

- NOTES
- (1) The work is best carried out in a Repair Stand (Part No 042-177).
 - (2) Refer to Para 9 for drawing information.
 - (3) When ordering replacement parts, Barrel (53), Baffle (54), Seal (55) and Cylinder (57) are supplied as an assembly. Always quote the Pump Number (see Identification Plate) and Barrel Letter Code (see Fig 4.2) when ordering.

13. Carry out a strip of the pump, as follows:

- (1) Carry out the procedure for removal of Diaphragms and Valves, as detailed in Para 11,
- (2) Unscrew the Bleed Screws (21) from the Bleed Rings (48) and remove the Bleed Rings.
- (3) Remove the socket-head Captive Screws (7) from the Cover Plate (10) with 'O' Ring (9) from the delivery side of the pump, then slacken Captive Screws (7) in Cover Plate (10) on the inlet side of the pump.
- (4) Slacken all Locknuts (47), half a turn only.
- (5) Unscrew all socket-head Set Screws (69) that are holding down the End Plate, and screw them into the adjacent tapped holes.
- (6) Tighten these Set Screws (69) down diametrically, until the End Plate is lifted. It may be necessary to put some freeing oil (WD 40) around the Barrels before starting to withdraw the End Plate.
- (7) Progressively add packing between Set Screws (69) and the Crankcase until the End Plate is clear of the Barrels. Alternatively, Set Screw (Part No 023-067) may be used dispensing with the need for packing.

NOTE If Barrels tend to come up with the lid as Set Screws are tightened (and Locknuts (47) are slackened), tap the Barrels down with a nylon mallet.

- (8) Working on one Barrel at a time, remove the Circlip (40) from the Gudgeon Pin (39). Remove by pushing Gudgeon Pin down.
- (9) Remove Locknut (47).
- (10) Disengage Piston (56) from the Con Rod (38), and remove Barrel Assembly.

NOTE Keep all components in individual Barrel Sets, ie when re-assembling use same Con Rod, Gudgeon Pin and Cylinder.

- (11) When all Barrel Assemblies have been removed, unscrew Nyloc Nut (29).
- (12) Lift off the Washer (28), inner race of the Floating Bearing (32), Counter Balance (23), Retaining Ring (37), and Con Rods (38), Eccentric (35) and Bearing (36), Counter Balance (23) and Key (27). The Shaft (25) can now be pulled out through location Bearing (31).

- (13) Remove Nyloc Nuts (17) and Washers (8), and lift off the Oil Seal Carrier (24) and Selector Support (58).
- (14) Using a small hand press and Dolly (Part No 201-007), remove Bearings (31 and 32).
14. Carry out a re-assembly of the pump, generally reversing the procedure used in Para 13, noting the following points:
- When replacing the Shaft, care should be taken to prevent the Shaft keyway from damaging the Oil Seal (10).
 - Barrels are letter coded and must be fitted in their correct position (Fig 4.2). All bleed holes in the Barrels must be in the vertical position.

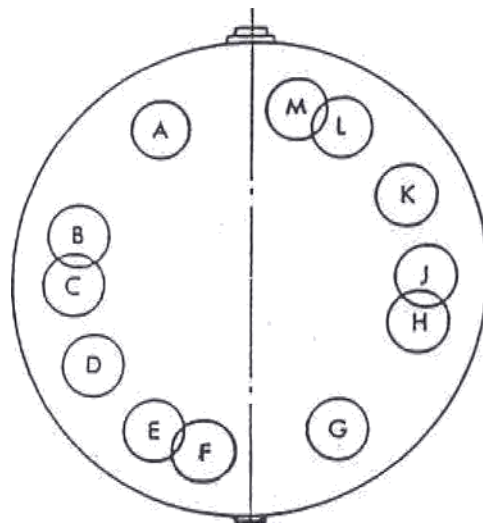

3 CYLINDER – AEJ
 4 CYLINDER - ADGK
 6 CYLINDER - ACEGJL
 8 CYLINDER - ABDFGHKM

VIEW ON FRONT (DELIVERY SIDE) OF PUMP

Fig 4.2 Pump Cylinder Code

- Fit new Gudgeon Pin Circlips (40) whenever they have been removed from the Gudgeon Pins.
- Gudgeon Pins with one Circlip already fitted should be inserted from beneath the Con Rods.
- Nyloc Nut (29) must be torqued to 135 Nm.

- f. When fitting the End Plate, ensure that the Locknuts (47) are slack. Tap down the End Plate as evenly possible, and then tighten the Locknuts (47) before tightening the Set Screws (69).
- g. Apply grease to the hose tail of the Valve Nut (41) to ease fitting of the Tee Moulding (M3)
- h. Apply grease to the outside of the Tee Moulding (M3) in the area of the Retaining Ring (37), to ease removal and assembly of the Retaining Ring over the Tee Moulding.

Pump Running In

15. Prior to running in the pump after overhaul or major component replacement, the pump should be filled with oil to the correct level. Refer to Lubrication Chart (Table 4.2) for details of recommended oil types and pump oil capacities, and Section 3, Para 18 (1) for pump oil level procedure.
16. The pump should also be bled of air in accordance with the procedures given in Section 3, Para's 18 and 19.
17. Run the pump at maximum pressure for 10 minutes, checking for leaks and monitoring the flow. Check the results against the pump performance data. The following points should be taken into account when determining maximum pressure to be used when running in the pump:
 - a. If the pump is being used on a system that has a lower working pressure than the maximum for the pump, then running in of the pump should be at the lower pressure.
 - b. Check the pump Identification Plate for the maximum working pressure of the pump before commencing the running in test. Some models of pumps have working pressures lower than stated, in which case running in should be carried out at the lower pressure.

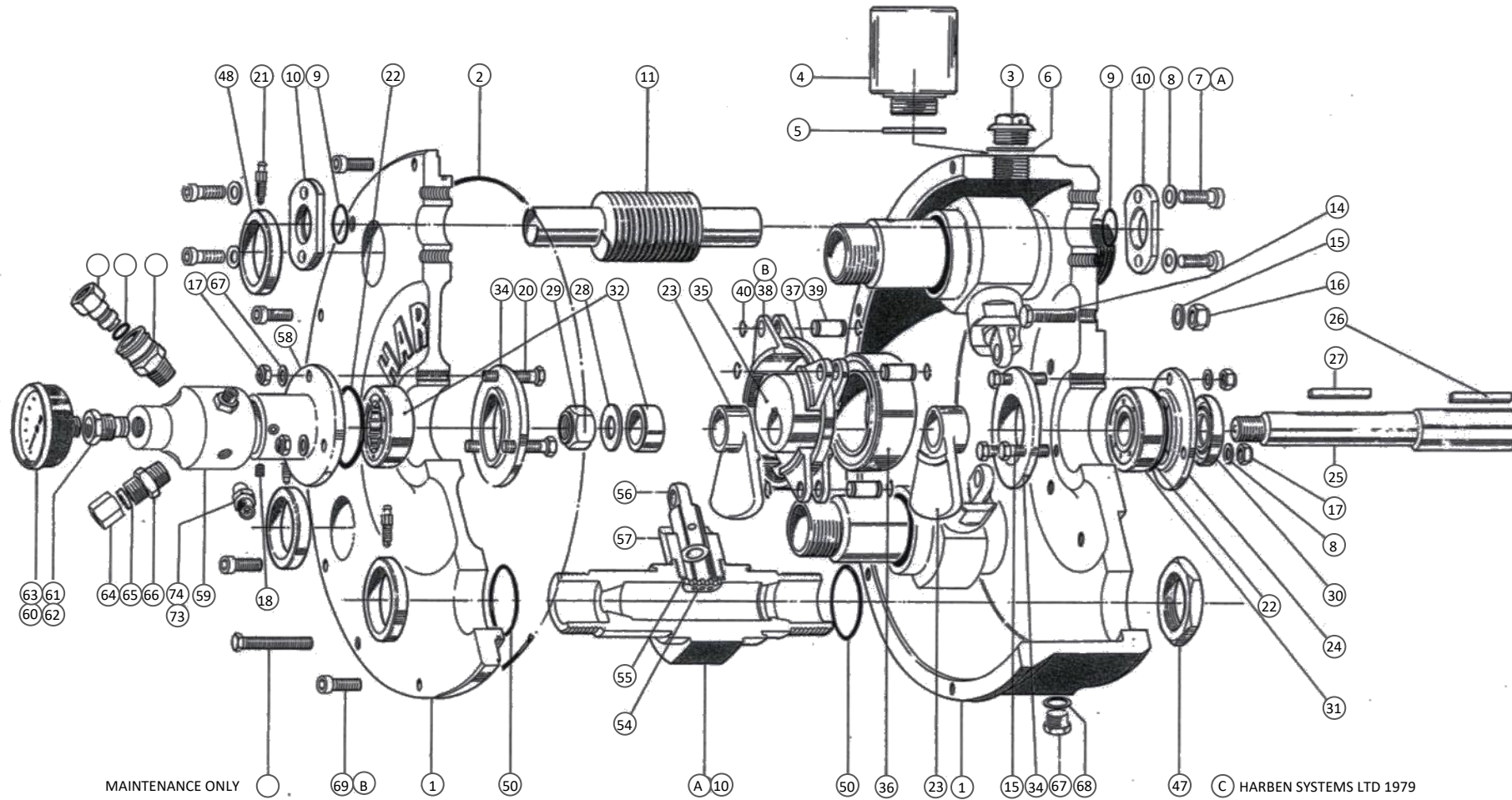

Fig 4.3 'P' Type – Pump Assembly

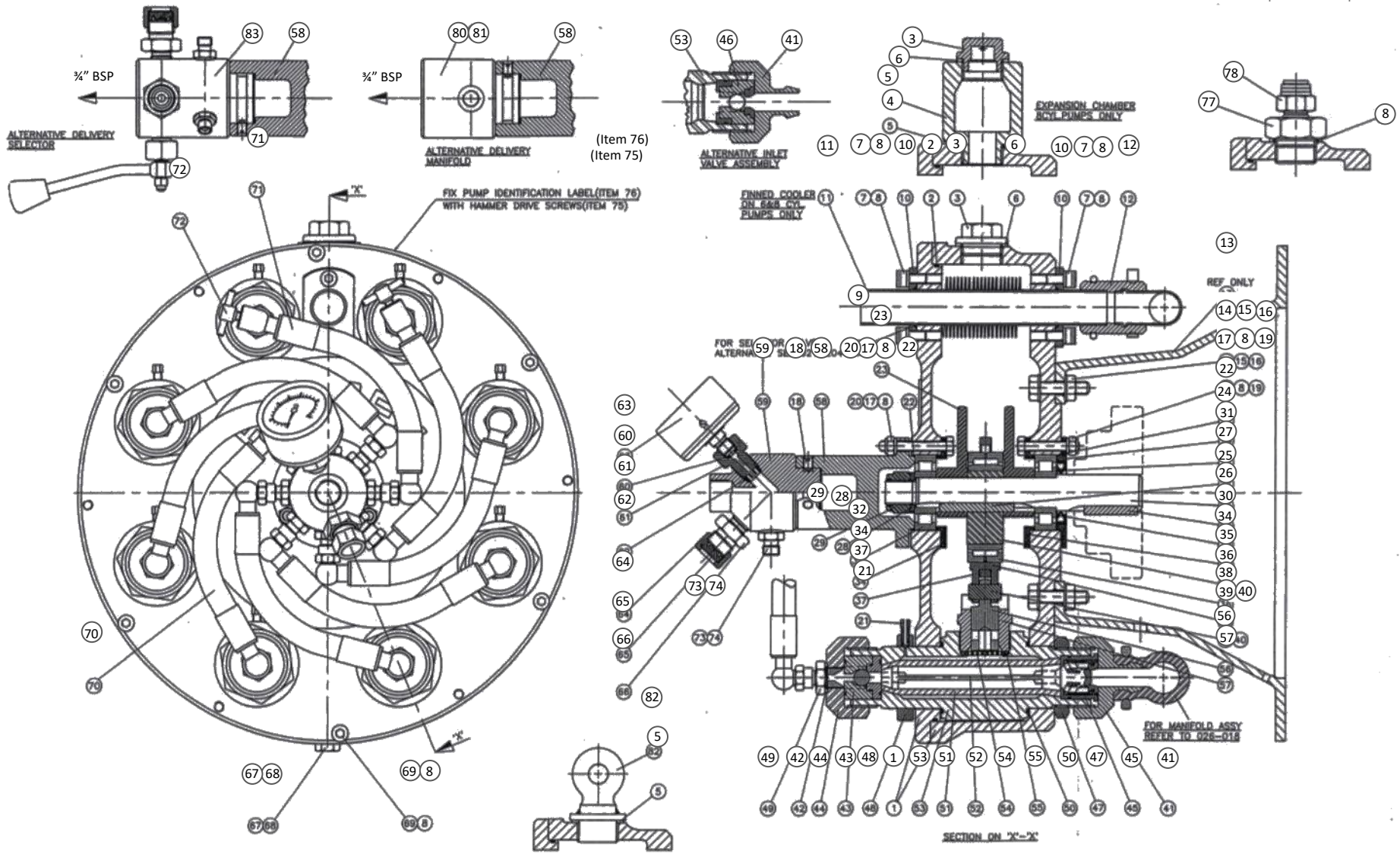

Fig 4.5 'P' Type – Pump Cross-Section

ITEM	PART NO	DWG NO	3 CYL	4 CYL	6 CYL	8 CYL	DESCRIPTION
1	011-101	011-176	1				CRANKCASE ASSEMBLY
	011-102	011-176	1				CRANKCASE ASSEMBLY
	011-103	011-176		1			CRANKCASE ASSEMBLY
	011-104	011-176			1		CRANKCASE ASSEMBLY
2	011-050	NONE	1	1	1	1	'O'RING 0.103" SECTION 70 SHORE
3	013-027	013-027	1	1	1	1	FILLER PLUG
4	013-041	013-041				1	EXPANSION CHAMBER
5	033-015	NONE	1	1	1	1	BONDED SEAL 1"BSP
6	013-139	NONE	1	1	1	1	WASHER 1"BSP SELON
7	013-084	NONE	4	4	4	4	SCREW CAP SOC.HD M8 x 16
8	013-090	NONE	16	16	16	16	WASHER SPRING M8
9	013-008	NONE	2	2	2	2	'O'RING BS122/70
10	012-059	012-059	2	2	2	2	COVER PLATE
11	012-079	011-172	1	1			OIL COOLER STRAIGHT
	012-200	012-200			1	1	OIL COOLER FINNED
12	011-220	026-018	1				INLET MANIFOLD ASSEMBLY
	011-221	026-018	1				INLET MANIFOLD ASSEMBLY
	011-222	026-018			1		INLET MANIFOLD ASSEMBLY
	011-223	011-223				1	INLET MANIFOLD ASSEMBLY
13		NONE	1	1	1	1	BELL HOUSING (REF ONLY)
14	013-093	NONE	7	6	6	6	SCREW SET HEX.HD. M10 x 45
15	013-029	NONE	6	6	6	6	WASHER PLAIN M10
16	013-030	NONE	6	6	6	6	NUT NYLOC M10
17	013-035	NONE	6	6	6	6	NUT NYLOC M8
18	013-067	NONE	11	11	11	11	SCREW SET SOC. M8 x 10
19	013-033	NONE	3	3	3	3	SCREW SET HEX.HD. M8 x 45
20	013-452	NONE	3	3	3	3	SCREW SET HEX.HD. M8 x 55
21	100-345	100-345	3	4	6	8	BLEED SCREW
22	013-049	NONE	2	2	2	2	'O'RING 0.070" SECTION
23	012-041	012-041	2	2	2	2	COUNTER BALANCE
24	012-066	012-066	1	1	1	1	OIL SEAL CARRIER
25	011-009	011-009	1	1	1	1	SHAFT
26	011-053	011-053	1	1	1	1	KEY 8 x 7 x 43
27	011-056	011-053	1	1	1	1	KEY 8 x 7 x 60
28	013-003	013-003	1	1	1	1	WASHER
29	013-004	013-004	1	1	1	1	NUT NYLOC M20 x 1.5

ITEM	PART NO	DWG NO	3 CYL	4 CYL	6 CYL	8 CYL	DESCRIPTION
30	013-155	NONE	1	1	1	1	OIL SEAL
31	013-006	NONE	1	1	1	1	BEARING LOCATION
32	013-005	NONE	1	1	1	1	BEARING FLOATING
33	023-093	NONE	1	1	1	1	COUPLING (REF ONLY)
34	012-009	012-009	2	2	2	2	BEARING RETAINER
35	012-005	012-005	1	1	1	1	ECCENTRIC
36	012-007	NONE	1	1	1	1	MAIN BEARING
37	012-004	012-004	1	1	1	1	RETAINING RING
38	011-071	011-015	3	4	6	8	CONNECTING ROD #18/#20 PISTONS
	011-015	011-015	3	4	6	8	CONNECTING ROD #22 PISTON
39	011-014	011-014	3	4	6	8	GUDGEON PIN
40	013-002	NONE	6	8	12	16	CIRCLIP 1400 x 12
41	011-216	011-217	3	4	6	8	VALVE NUT BRASS ONE PIECE
	011-217	011-217	3	4	6	8	VALVE NUT ST/ST ONE PIECE
42	033-013	NONE	3	4	6	8	SEAL BONDED 3/8"BSP
43	011-060	011-060	3	4	6	8	VALVE DELIVERY ASSEMBLY
44	011-116	011-116	3	4	6	8	VALVE NUT BRASS
	011-117	011-116	3	4	6	8	VALVE NUT ST/ST
45	011-166	011-166	3	4	6	8	VALVE INLET HIGH LIFT
46	011-048	011-048	3	4	6	8	VALVE INLET
47	012-011	012-011	3	4	6	8	LOCKNUT 1 1/2"BSP BRASS
48	012-014	012-014	3	4	6	8	BLEED RING
49	013-145	013-145	3	4	6	8	ADAPTOR 3/8"BSP x 1/4"BSP
50	013-011	NONE	6	8	12	16	'O'RING BS135/60
51	012-032	012-032	3	4	6	8	DIAPHRAGM
52	012-033	012-033	3	4	6	8	MANDREL
53	011-163	011-066	3	4	6	8	BARREL EN1A SLABBED
	011-229	011-066	3	4	6	8	BARREL EN57 SLABBED
54	012-001	012-001	3	4	6	8	BAFFLE
55	011-011	011-011	3	4	6	8	SEAL INNER CYLINDER
56	012-090	012-090	3	4	6	8	PISTON #18
	012-091	012-091	3	4	6	8	PISTON #20
	012-092	012-092	3	4	6	8	PISTON #22
57	011-067	011-069	3	4	6	8	CYLINDER #18
	011-068	011-069	3	4	6	8	CYLINDER #20
	011-069	011-069	3	4	6	8	CYLINDER #22

ITEM	PART NO	DWG NO	3 CYL	4 CYL	6 CYL	8 CYL	DESCRIPTION
58	012-026	011-149	1	1	1	1	SELECTOR SUPPORT
59	011-123	011-127	1				MANIFOLD BODY ST/ST
	011-124	011-127		1			MANIFOLD BODY ST/ST
	011-125	011-127			1		MANIFOLD BODY ST/ST
	011-126	011-127				1	MANIFOLD BODY ST/ST
60	061-067	061-067	1	1	1	1	SEATING WASHER
61	011-219	NONE	1	1	1	1	ADAPTOR FOR GAUGE
62	032-168	032-167	1	1	1	1	SEAL 3/8"BSP NYLON
63	012-096	NONE	1	1	1	1	PRESSURE GAUGE 0-6000 PSI
	013-290	NONE	1	1	1	1	PRESSURE GAUGE 0-10000 PSI
64	013-043	013-043	1	1	1	1	HOLDER FOR PRESSURE DISC
65		011-019	1	1	1	1	PRESSURE DISC (TO SUIT)
66	023-335	023-335	1	1	1	1	ADAPTOR PRESSURE DISC
67	013-490	NONE	1	1	1	1	DRAIN PLUG 3/8"BSP
68	013-026	NONE	1	1	1	1	SEAL DRAIN PLUG 3/8"BSP
69	013-430	NONE	6	6	6	6	SCREW SET SOC.HD. M8 x 25
70	012-137	012-137	2	2	4	6	TOP HOSE
71	012-138	012-137	1	2	2	2	TOP HOSE AIR BLEED
72	011-165	011-165	1	2	2	2	BLEED SCREW WATER
73	033-012	NONE	3	4	6	8	BONDED SEAL 1/4"BSP
74	013-144	013-144	3	4	6	8	
75	013-232	NONE	6	6	6	6	SCREW HAMMER DRIVE
76	043-110	043-110	1	1	1	1	LABEL PUMP IDENTIFICATION
77	023-360	NONE	1	1	1	1	ADAPTOR 1"BSP x 1/2"BSP
78	023-013	NONE	1	1	1	1	CAP BLANKING 1/2"BSP
80	011-226	011-226			1		DELIVERY MANIFOLD
81	011-227	011-226				1	DELIVERY MANIFOLD
82	061-077	061-077	1	1	1	1	LIFTING EYE
83	021-204	021-2041	1				SELECTOR ASSEMBLY (ST/ST)
	021-205	021-2041		1			SELECTOR ASSEMBLY (ST/ST)
	021-206	021-2041			1		SELECTOR ASSEMBLY (ST/ST)
	021-113	021-2041				1	SELECTOR ASSEMBLY (ST/ST)
	021-095	021-2041	1				SELECTOR ASSEMBLY (BRASS)
	021-096	021-2041		1			SELECTOR ASSEMBLY (BRASS)
	021-097	021-2041			1		SELECTOR ASSEMBLY (BRASS)
	021-098	021-2041				1	SELECTOR ASSEMBLY (BRASS)

Fig 4.6 'P' Type Pump-Pump Parts List

ITEM	PART NO	3	4	6	8	DESCRIPTION
		CYL	CYL	CYL	CYL	
1	011-215	1	1	1	1	Connector Tee Tube - Cooler
2	011-203	3	4	6	8	Retaining Ring
3	011-204	3	4	6	8	Tee Moulding
4	014-033	2	2	2	2	Spring Clip
5	014-051	6	8	12	16	Hose Clamp Double Bonded
6	011-209	1	-	-	-	Tee Tube 3 Cyl
	011-213	-	1	-	-	Tee Tube 4 Cyl
	011-214	-	-	1	-	Tee Tube 6 Cyl
	011-207	-	-	-	1	Tee Tube 8 Cyl
7	011-212	2	-	-	-	Tube 3 Cyl
	011-210	-	3	-	-	Tube 4 Cyl
	011-211	-	-	5	-	Tube 6 Cyl
	011-208	-	-	-	7	Tube 8 Cyl
8	011-216	3	4	6	8	Valve Nut Brass
	011-217	3	4	6	8	Valve Nut ST/ST

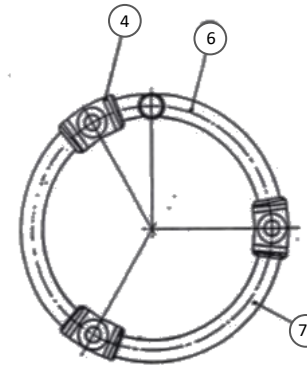

3-CYL. ASS. PART NO. 011-220

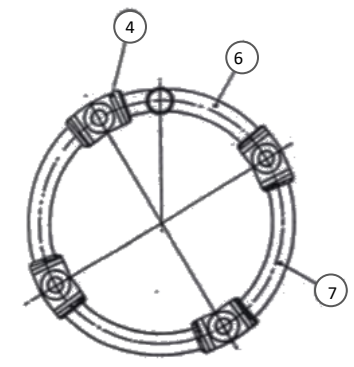

4-CYL. ASS. PART NO. 011-221

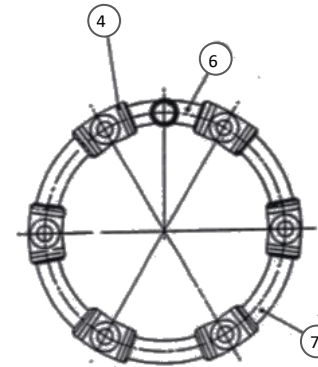

6-CYL. ASS. PART NO. 011-222

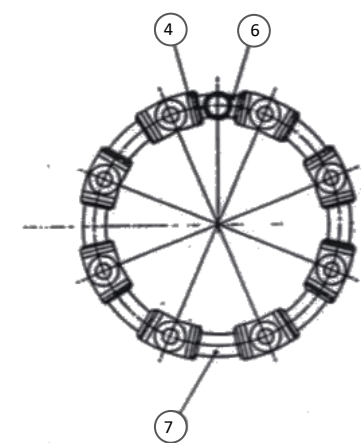

8-CYL. ASS. PART NO. 011-223

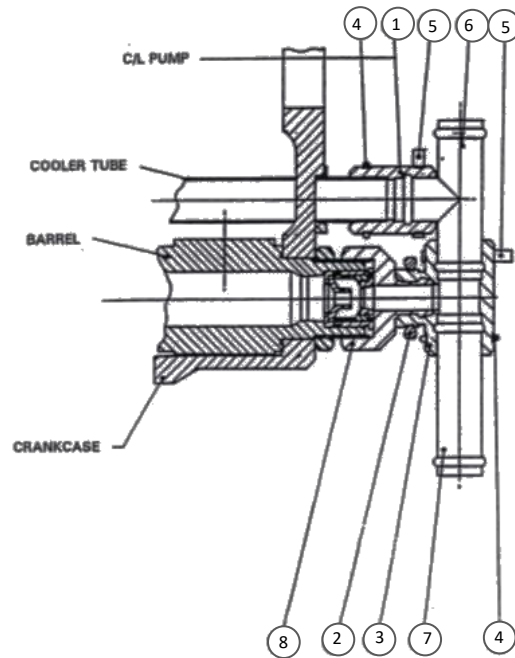

Fig 4.7 'P' Type Pump- Inlet Manifold Assembly

ITEM	PART_NO	3CYL	4CYL	6CYL	8CYL	DESCRIPTION
1	022-001	1	-	-	-	Body Selector Brass
1	022-002	-	1	-	-	Body Selector Brass
1	022-003	-	-	1	-	Body Selector Brass
1	022-004	-	-	-	1	Body Selector Brass
1	022-051	1	-	-	-	Body Selector Stainless Steel
1	022-050	-	1	-	-	Body Selector Stainless Steel
1	022-049	-	-	1	-	Body Selector Stainless Steel
1	022-048	-	-	-	1	Body Selector Stainless Steel
2	022-017	1	1	1	1	Shaft Eccentric
3	021-003	1	1	1	1	Nut Gland Brass
4	023-001	1	1	1	1	Back up ring BS111
5	013-021	2	2	2	2	'O' Ring BS111/90
6	012-095	1	1	1	1	Seal
7	021-001	1	1	1	1	Support
8	022-016	1	1	1	1	Plug
9	022-008	3	3	3	3	Fitting Brass
10	021-016	3	3	3	3	Seat
11	022-009	2	2	2	2	Guide
12	033-012	3	4	6	8	Seal Bonded 1/4" BSP
13	023-002	1	1	1	1	Knob
14	022-007	1	1	1	1	Lever
15	023-004	1	1	1	1	Nut Nyloc M6
16	023-003	1	1	1	1	Washer Plain M6
17	013-043	1	1	1	1	Holder Pressure Disc
18	013-144	1	1	1	1	Pressure Disc (To Suit Adaptor 1/4" BSP X 1/4" BSP
19	013-144	3	4	6	8	Washer Seating
20	061-067	1	1	1	1	Fitting pressure gauge
21	011-023	1	1	1	1	Locknut 1/2" BSP
22	033-066	1	1	1	1	Nut gland ST/ST
23	012-121	1	1	1	1	Fitting ST/ST
24	012-120	3	3	3	3	Pressure gauge 0-6000 psi (ref only)
25	012-096	1	1	1	1	Pressure gauge 0-10000 psi (ref only)
26	013-290	1	1	1	1	Pressure gauge 0-10000 psi (ref only)

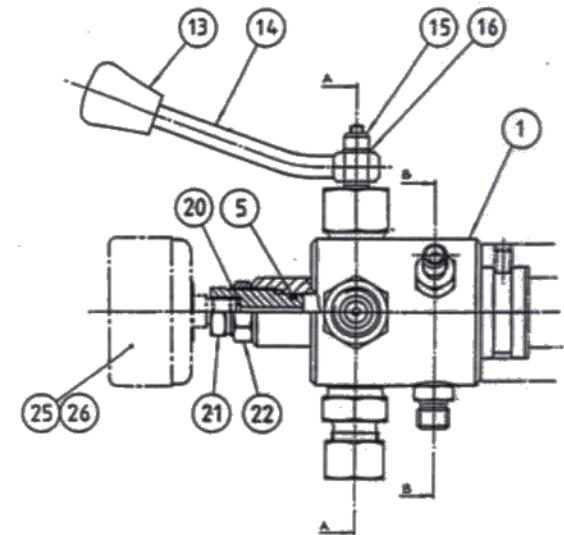
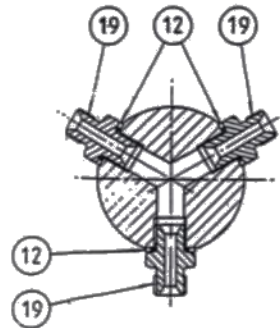
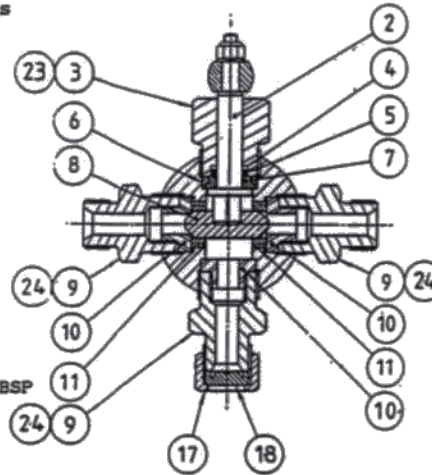

Fig 4.8 Manifold Selector Assembly

<u>ITEM</u>	<u>PART NO</u>	<u>QTY</u>	<u>DESCRIPTION</u>	<u>REMARKS</u>
1	033-027	1	Body	
2	022-017	1	Shaft	
3	021-003	1	Nut Gland	
4	023-001	1	Back Up Ring	
5	013-021	1	'O' Ring	
6	012-095	1	Seal	
7	021-001	1	Support	
8	022-016	1	Plug	
9	022-008	2	Fitting	
10	021-016	2	Seat	
11	022-009	2	Guide	
12	033-012	1	Seal Bonded 1/4" BSP	
13	023-002	1	Knob	
14	022-007	1	Lever	
15	023-004	1	Nut Nyloc M6	
16	023-003	1	Washer M6	
17	013-140	1	Plug Blanking	
18	013-039	1	Connector 1/2" BSP X 1/2" BSP Fitting JIC	
19	032-058	2		
20	033-010	1	Bonded Seal 1/2" BSP	

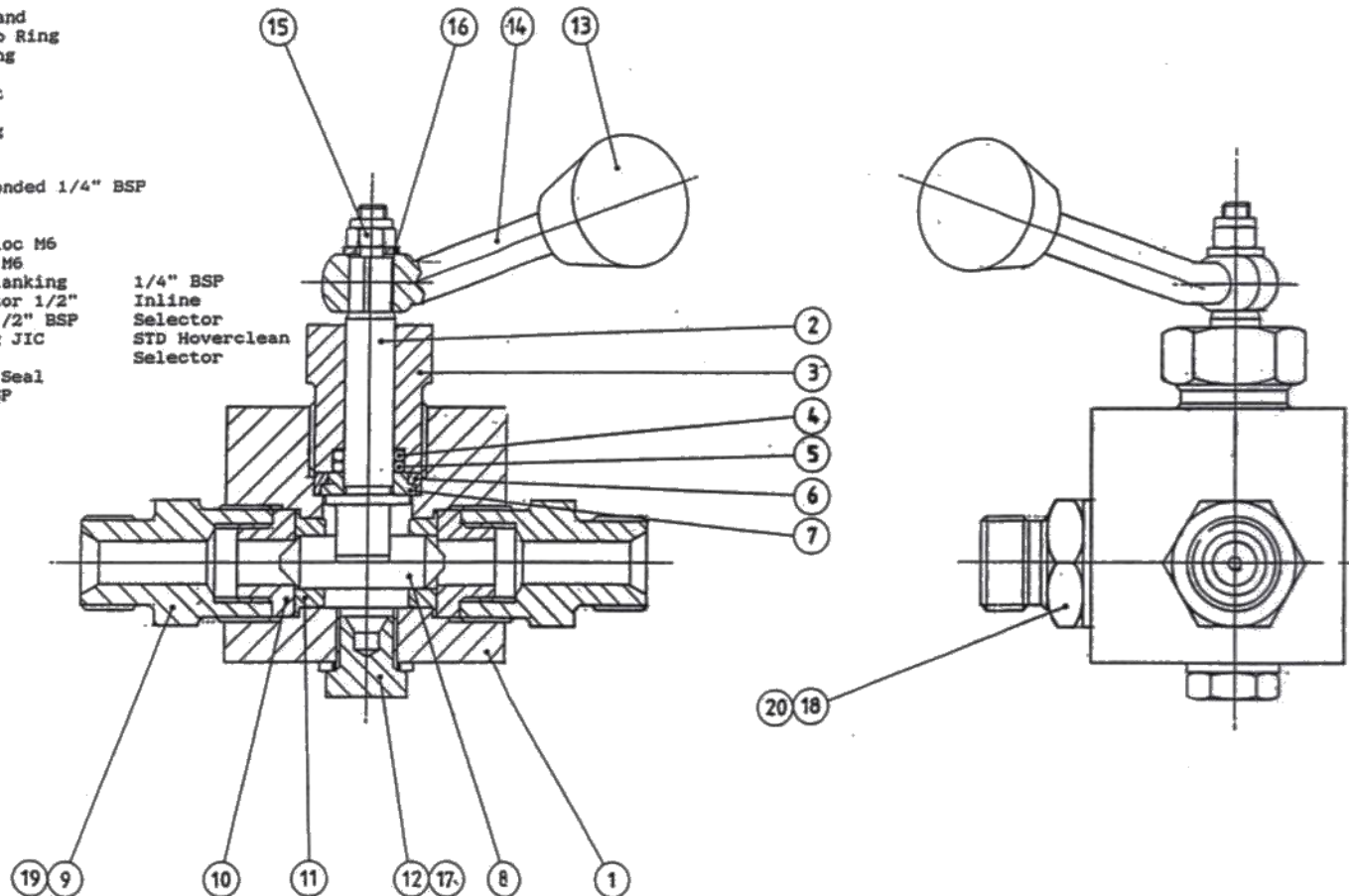

Fig 4.9(a) Inline selector Assembly

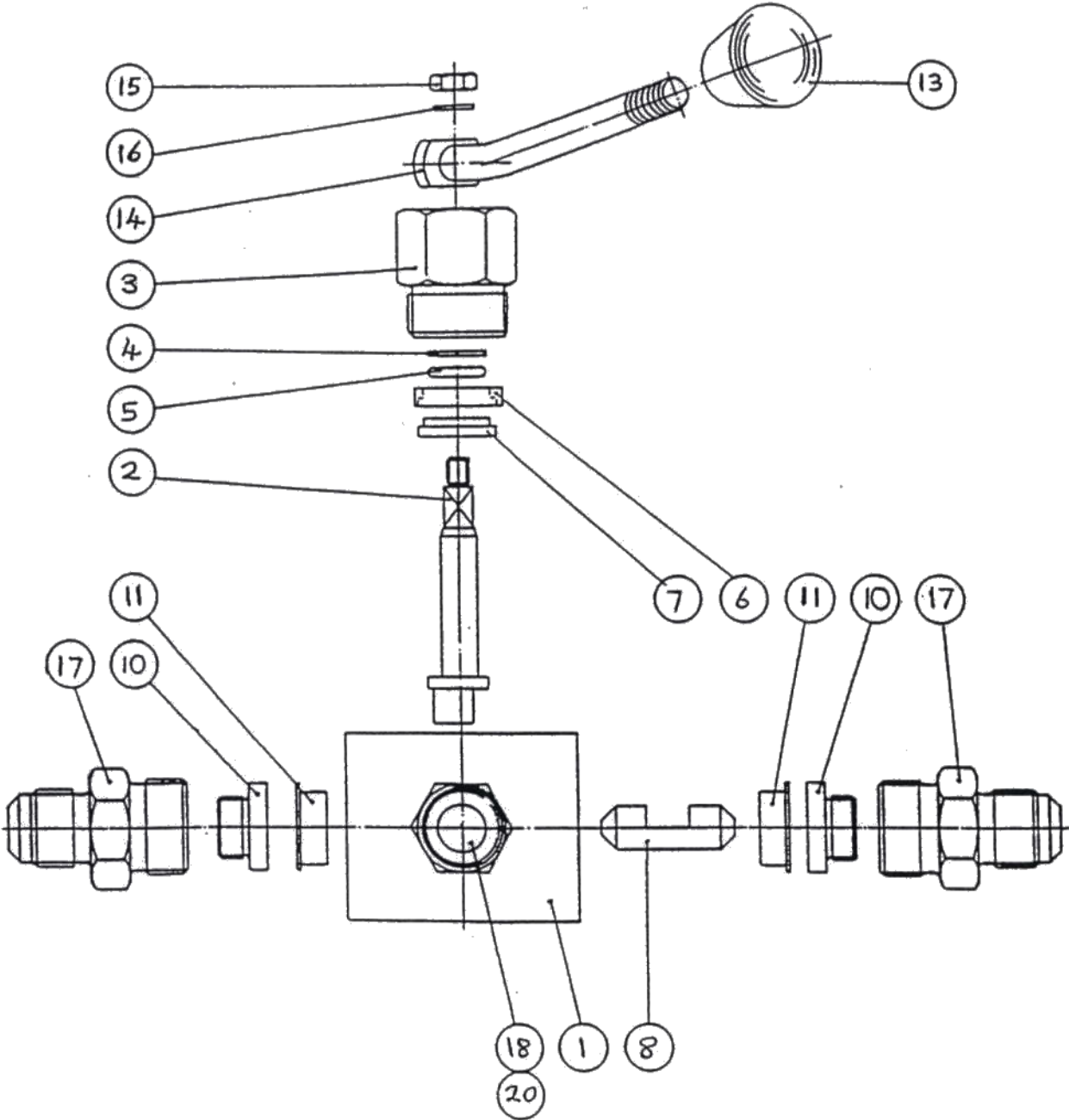

Fig 4.9(b) Inline Selector Assembly

SECTION 5

WARRANTY

SECTION 5

WARRANTY

	<u>Page</u>
Warranty	
Warranty of New Products	66
Warranty of Spare Parts	66
Limitations of Warranty	
Non Warranty Items	67-69
Service and Spares	69

WARRANTY

Warranty of New Products

Equipment manufactured and supplied by Flowplant is warranted to be free from defects in materials and workmanship.

The warranty includes both parts and labour necessary to correct any such defects.

The warranty period for new products is 12 months from date of despatch from our factory or 2000 operating hours, whichever occurs soonest.

We shall repair or, at our option, replace free of charge any product, part(s) or component(s) manufactured by Flowplant which fail due to faulty manufacture or material within the warranty period.

Warranty of Spare Parts

The warranty for new spare parts is 6 months from date of despatch on materials and workmanship or 250 operating hours, whichever occurs soonest.

The warranty for reconditioned spare parts is 90 days from date of despatch on materials and workmanship.

Provided always that

- a) They are returned to Flowplant for inspection (carriage paid), along with a copy of the original part(s) sale invoice (where necessary); and
- b) All terms agreed by Flowplant for payment of such goods have been complied with; and
- c) If a defect/failure is discovered before the expiration of the warranty, notification must be given to the Flowplant service department immediately
- d) Any claim hereunder is made within 30 days of the date of discovery of the defect/failure.

Provision of this warranty shall not apply to any Flowplant product which has been:

- a) Used for a purpose for which it is not designed for; or
- b) Applied to a use which has not been approved by Flowplant; or
- c) Subject to misuse, negligence, lack of maintenance or accident; or
- d) Repaired or altered in any way so as, in the judgment of Flowplant, to adversely affect its performance and reliability

Limitations of Warranty

The new product and spare parts warranty is limited to defects in material or workmanship of the product. It does not cover loss of time, inconvenience, property damage or any consequential damages. Repair or replacement of the product is your exclusive remedy.

Our liability under this clause shall be in lieu and to this exclusion of any warranty or conditions implied or expressed by law as to the quality or fitness for purpose of any goods supplied hereunder PROVIDED THAT nothing in this clause shall operate so as to exclude liability for death or personal injury arising from the negligence of the company or its employees.

Our obligations as aforesaid shall constitute the full extent of our liability in respect of any loss or damage sustained by the purchaser whether caused by any breach of this contract or by our negligence or otherwise and we shall not be liable to make good or pay for loss of use of the goods, loss of revenue, loss of profit or goodwill or any direct or consequential losses howsoever caused and the purchaser undertakes to indemnify us against any such claims against us by third parties.

On order to comply with the provision of the Health and Safety at work etc., Act 1974 in respect of articles manufactured, supplied or installed for use at work we test all our products before they leave our factory and supply them with adequate instructions for their proper use. Further copies of these instructions are available from us upon request.

Non Warranty Items

The Warranty terms are a precise statement of Flowplant Group Ltd's intention to cover the replacement or repair cost, on a standardised and agreed basis, of any product failure resulting from defective material or sub-standard workmanship during the manufacturing process.

The following items are considered to be of a Maintenance nature and should not be subject of a claim.

Engine (Manufacturers Warranty Applies)

- Routine servicing of injector/fuel injection equipment.
- Heavy fuel consumption rectified by engine adjustment.
- Adjustment of fan belts/throttle and controls.
- Tightening of all sump and cover bolt/nuts water connections and exterior oilpipes and filter bolts.
- Filters and the cleaning of filters.
- Engine service components.
- Adjustments.

Brakes (Trailer)

- Brake shoe adjustment/bleeding and topping up of reservoir/draining of air systems where not due to a defective part.
- Brake squeal from brake linings.
- Replacement of linings due to fair wear and tear.
- Tightness of air lines/pipes.
- Filters and the cleaning of filters.
- Brake fluid.

Electrical (all products) Manufacturers Warranty Applies

- Cleaning of terminals.
- General maintenance of batteries, dynamo/alternator, starter etc.
- Adjustment to ignition system components.
- General adjustment to electrical control current settings.
- Brushes and other items due to fair wear and tear.
- Contactor tips and springs.
- Replacement of lamps, lenses and bulbs.

Steering/Running Gear

- Front wheel alignment, track adjustment.
- Steering adjustment.
- Hub bearing and float adjustment.
- Jockey wheels.

Hydraulics (all products)

- Tightening of hydraulic fittings and couplings.
- Filters and the cleaning of filters.
- Hydraulic fluid.

Chassis (self-propelled and trailer-mounted units)

- General rattles.
- Paint chips.
- Alignment and adjustment of panels etc.
- Deterioration of paint and external fittings due to neglect, exposure and fair wear and tear.
- Accidental damage.

Lubrication (all products)

- Complete or partial lubrication services.

Corrosion (all product)

- Damage caused by adverse weather/atmosphere conditions.

General (all products)

- Fair wear and tear.
- Any work carried out to improve the general finish of the machine above what is known to be the factory standard.
- Failure to maintain the equipment in accordance with the manufacturer's recommendations.

REMEMBER:

- i. The replacement or repair of tyres is not covered by the Company's warranty terms.
- ii. In the case of van and truck mounted equipment the warranty relating to the actual vehicle remains the responsibility of the vehicle manufacturer or supplier.

In order to comply with the provisions of the Health and Safety at Work Act 1974 in respect of articles manufactured, supplied or installed for use at work, we test all our products before they leave our factory and supply with them adequate instructions for their proper use. Further copies of these instructions are available from us on request.

We shall not be liable for loss, injury or damage of whatever nature caused by goods, design, technical information, suggestions, etc supplied by us where as the case maybe they have been structurally modified or misused or misapplied or have not been properly cared for and maintained, and the purchaser hereby agrees to indemnify us against all such claims and demands or by whomsoever they are brought.

Service and Spares

Flowplant provide service and spares cover in most parts of the world. When ordering spares, please quote:-

- a) Your company name and address.
- b) Destination of parts, if different from above.
- c) Description and part number.
- d) Quantity required.
- e) Price and method of payment.
- f) Delivery date.
- g) Order number.
- h) Confirmation of order

When requesting service or repairs, please state:-

- a) Your company name and address.
- b) Location of machine/unit if different from above.
- c) Type and model of machine/unit.
- d) Pump serial number.
- e) Problem(s) with machine/unit.
- f) Availability of machine/unit for service or repairs.
- g) Date of service and site contract.
- h) Cost and method of payment.
- i) Order number.
- j) Confirmation of order.